

# S80 / S8

Digital speed to fly variometer, final glide calculator and navigation system with simple moving map.

Version 5.01



LXNAV d.o.o. • Kidričeva 24a, 3000 Celje, Slovenia • tel +386 592 33 400 fax +386 599 33 522  
[info@lxnav.com](mailto:info@lxnav.com) • [www.lxnav.com](http://www.lxnav.com)

<b>1</b>	<b>Important Notices</b>	<b>5</b>
<b>1.1</b>	<b>Limited Warranty</b>	<b>5</b>
<b>2</b>	<b>Packing Lists</b>	<b>6</b>
<b>3</b>	<b>Basics</b>	<b>7</b>
<b>3.1</b>	<b>LXNAV S80 at a Glance</b>	<b>7</b>
3.1.1	LXNAV S80 Features	7
3.1.2	Interfaces	8
3.1.3	Options	8
3.1.3.1	External Options	8
3.1.4	Technical Data	8
<b>4</b>	<b>System Description</b>	<b>9</b>
4.1.1	Push Button	9
4.1.1.1	Power Button	9
<b>4.2</b>	<b>Rotary Switches</b>	<b>9</b>
<b>4.3</b>	<b>Switching on the Unit</b>	<b>10</b>
<b>4.4</b>	<b>User Input</b>	<b>11</b>
4.4.1	Text Edit Control	11
4.4.2	“Spin” Control	11
4.4.3	Selection Control	12
4.4.4	Checkbox and Checkbox List	13
4.4.5	Slider selector	13
<b>4.5</b>	<b>Switching off</b>	<b>14</b>
<b>5</b>	<b>Operating Modes</b>	<b>15</b>
<b>5.1</b>	<b>Info Screen</b>	<b>16</b>
5.1.1	Quick access menu	16
<b>5.2</b>	<b>Flarm Screen</b>	<b>17</b>
5.2.1	Quick access menu	17
5.2.2	Flarm warnings	18
<b>5.3</b>	<b>Waypoint Screen</b>	<b>18</b>
5.3.1	Quick access menu	19
5.3.1.1	Navboxes Option	20
5.3.1.2	Editing Navboxes	21
5.3.2	Second Waypoint Page (Numerical Data)	22
5.3.3	Third Waypoint Page (AHRS)	23
5.3.4	Quick access menu	24
5.3.4.1	Editing Navboxes	24
5.3.4.2	Reset bar	24
<b>5.4</b>	<b>Task Screen</b>	<b>25</b>
5.4.1	Quick access menu	26
5.4.2	Second Task Page (Numerical Data)	27
5.4.3	Third Task Page (AHRS)	28
5.4.4	Quick access menu	29
5.4.4.1	Editing Navboxes	29
5.4.4.2	Reset bar	29
<b>5.5</b>	<b>Thermal Assistant page</b>	<b>31</b>
<b>5.6</b>	<b>Setup Screen</b>	<b>31</b>
5.6.1	QNH & RES	33
5.6.1.1	QNH	33
5.6.1.2	Safety Altitude	33
5.6.2	Vario Param.	34

5.6.2.1	Vario needle filter	34
5.6.2.2	Vario sound filter	34
5.6.2.3	Netto filter	34
5.6.2.4	Relative filter	34
5.6.2.5	SC filter	34
5.6.2.6	Smart Filter	34
5.6.2.7	Needle range	35
5.6.2.8	Dead Band (SC tab)	35
5.6.2.9	Auto SC	35
5.6.2.10	Vario Average Time	35
5.6.2.11	Netto Average Time	35
5.6.2.12	Temperature Offset	35
5.6.2.13	Inertial assisted vario	35
5.6.3	Thermaling Assistant	36
5.6.3.1	Colour circles by	36
5.6.3.2	Switch to thermal assistant	36
5.6.4	Display	37
5.6.4.1	Automatic Brightness	37
5.6.4.2	Minimum Brightness	37
5.6.4.3	Maximum Brightness	37
5.6.4.4	Brightness	37
5.6.5	Graphics	38
5.6.5.1	Graphics – Flarm	38
5.6.5.2	Colours can be set for the following:	38
5.6.5.3	Label Text	38
5.6.5.4	Active Timeout	39
5.6.5.5	Inactive Timeout	39
5.6.5.6	Draw Line to selected Target	39
5.6.5.7	Draw History	39
5.6.5.8	Plane icon size	39
5.6.5.9	Graphics – Airsp. & Tsk.	39
5.6.6	Sounds	40
5.6.6.1	Equalizer Option	40
5.6.6.2	Vario Sounds	41
5.6.6.3	Flarm Sounds	42
5.6.7	Warnings	43
5.6.8	Obs. Zones	43
5.6.9	Units	44
5.6.10	Hardware	45
5.6.10.1	Vario Setup	45
5.6.11	Indicator setup	47
5.6.12	Comms. Setup	48
5.6.13	Battery Chemistry Setup	48
5.6.14	Files	50
5.6.14.1	Waypoints File	50
5.6.14.2	Airspace File	51
5.6.14.3	Flarmnet File	52
5.6.15	Polar and Glider	52
5.6.16	Logbook	54
5.6.17	Password	55
5.6.17.1	List of Password functions	55

5.6.18	About	55
<b>6</b>	<b>Variometer and Altimeter</b>	<b>56</b>
6.1	Altimeter	56
6.2	Speed Command	56
<b>7</b>	<b>Flying with the LXNAV S80</b>	<b>57</b>
7.1	On the Ground	57
7.1.1	Power on Procedure	57
7.1.2	Set Elevation and QNH	57
7.1.3	Pre-flight Check	58
7.2	Airborne	58
7.2.1	Final glide calculation	58
<b>8</b>	<b>Installation</b>	<b>59</b>
8.1	Installing the LXNAV S80	60
8.2	Connecting LXNAV S80	60
8.3	Cutout of S80	61
8.4	Available cables for GPS and PDA ports	61
8.5	Installation of options	62
8.5.1	S80D option (S80 repeater)	62
8.5.1.1	Data Exchange	62
8.5.1.2	Cable Wiring (LXNAV S80D)	62
8.5.2	Magnetic compass (Compass -CAN)	63
8.5.3	Remote stick (Remote-CAN)	63
8.5.4	AHRS option	63
8.6	Ports and Wiring	64
8.6.1	LXNAV S80 ports	64
8.6.1.1	PDA port (RJ45)	64
8.6.1.2	GPS port (RJ11)	65
8.6.1.3	Main port	65
8.6.1.4	Audio port	65
8.6.2	LXNAV S80 wiring	65
8.7	Configurations	66
8.7.1	NANO – S80 – OUDIE	66
8.7.2	NANO – S80 – MINIMAP	66
8.7.3	Nano3– S80 – OUDIE	66
8.7.4	COLIBRI2 – S80 – OUDIE	67
8.7.5	COLIBRI,VOLKSLOGGER– S80 – OUDIE	67
8.7.6	Flarm/RedBox– S80 – OUDIE	67
8.7.7	FlarmMouse - FlarmView -S80 - OUDIE	68
8.7.8	FlarmMouse – S80 – OUDIE	68
<b>9</b>	<b>Firmware Update</b>	<b>69</b>
9.1	Updating LXNAV S80 firmware using micro SD card	69
<b>10</b>	<b>Revision History</b>	<b>70</b>

## 1 Important Notices

The LXNAV S80 system is designed for VFR use only as an aid to prudent navigation. All information is presented for reference only. Terrain, airports and airspace data are provided only as an aid to situation awareness.

Information in this document is subject to change without notice. LXNAV reserves the right to change or improve their products and to make changes in the content of this material without obligation to notify any person or organisation of such changes or improvements.



A Yellow triangle is shown for parts of the manual which should be read carefully and are important for operating the LXNAV S80 system.



Notes with a red triangle describe procedures that are critical and may result in loss of data or any other critical situation.



A bulb icon is shown when a useful hint is provided to the reader.

### 1.1 Limited Warranty

This LXNAV S80 product is warranted to be free from defects in materials or workmanship for two years from the date of purchase. Within this period, LXNAV will, at its sole option, repair or replace any components that fail in normal use. Such repairs or replacement will be made at no charge to the customer for parts and labour, the customer shall be responsible for any transportation cost. This warranty does not cover failures due to abuse, misuse, accident, or unauthorised alterations or repairs.

THE WARRANTIES AND REMEDIES CONTAINED HEREIN ARE EXCLUSIVE AND IN LIEU OF ALL OTHER WARRANTIES EXPRESSED OR IMPLIED OR STATUTORY, INCLUDING ANY LIABILITY ARISING UNDER ANY WARRANTY OF MERCHANTABILITY OR FITNESS FOR A PARTICULAR PURPOSE, STATUTORY OR OTHERWISE. THIS WARRANTY GIVES YOU SPECIFIC LEGAL RIGHTS, WHICH MAY VARY FROM STATE TO STATE.

IN NO EVENT SHALL LXNAV BE LIABLE FOR ANY INCIDENTAL, SPECIAL, INDIRECT OR CONSEQUENTIAL DAMAGES, WHETHER RESULTING FROM THE USE, MISUSE, OR INABILITY TO USE THIS PRODUCT OR FROM DEFECTS IN THE PRODUCT. Some states do not allow the exclusion of incidental or consequential damages, so the above limitations may not apply to you. LXNAV retains the exclusive right to repair or replace the unit or software, or to offer a full refund of the purchase price, at its sole discretion. SUCH REMEDY SHALL BE YOUR SOLE AND EXCLUSIVE REMEDY FOR ANY BREACH OF WARRANTY.

To obtain warranty service, contact your local LXNAV dealer or contact LXNAV directly.

## 2 Packing Lists

- LXNAV S80
- Main power cable for S80 + CAN terminator
- Speaker
- GPS cable – V7-GPS-IGC

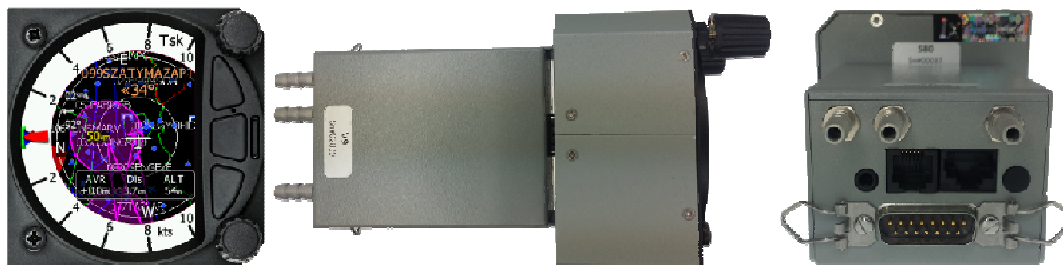

## 3 Basics

### 3.1 LXNAV S80 at a Glance

LXNAV S80 is standalone digital vario meter, final glide calculator and navigation system with simple moving map. The LXNAV S80 has both GPS/Flarm and PDA/PNA inputs/outputs. The unit has standard dimensions that will fit into a glider panel with an opening of - 80 mm diameter (3.15"). It is also able to supply PDA/PNA with power (5VDC/1A). The unit has an integrated high precision digital pressure sensor and inertial system. The sensors are sampled more than 100 times per second. Real time Data is indicated with the vario needle, airspace map and up to 4 variable number fields displayed on QVGA 320x240 pixel, 3.5 inch, high brightness (1200 nits) colour display. To adjust values and settings, the LXNAV S80 has two rotary push button knobs and three additional push buttons.

The LXNAV S80 can be expanded with one or more repeaters (LXNAV S80D) through the CAN bus. This allows both pilots in a two seat glider to have independent control of all functions of each unit in the front or the rear seat.



#### 3.1.1 LXNAV S80 Features

- Extremely bright 3.5" 8.9cm QVGA colour display readable in all sunlight conditions with the ability to adjust the backlight .
- Two rotary switches (knobs) with push button function and three push buttons are used for input.
- Pre-loaded polar database for almost all gliders.
- GPS/Flarm and PDA/PNA inputs/outputs
- Flarm Indication, if Flarm is connected to the GPS/Flarm port
- Programmable "needles" for selectable data such as netto vertical speed, relative (super netto) and vertical speed (vario).
- 320x240 pixels colour screen for additional information such as average, thermal vario, time, speed etc...
- Many custom audio settings
- 100Hz sampling rate for very fast response.
- Speed to fly indication.
- TE compensation can be selected to be either pneumatic TE probe or electronic TE.
- Multilanguage user interface - in a future firmware release

- Audio equalizer, for custom vario sound performance

### 3.1.2 Interfaces

- GPS/Flarm port input/output on RS232 level (RJ11 connector, not Standard IGC)
- PDA port input/output on RS232 or LV-TTL (3.3V) level for PNA devices (RJ45 connector)
- Audio port (Standard 3mm phono jack)
- 1Mbit CAN bus for extension to S80D repeater

### 3.1.3 Options

#### 3.1.3.1 External Options

By using a CAN bus system, a second seat device can be connected. The unit installed in the rear seat of the glider is independently powered and receives all the necessary data from the main unit. The communication between both units is exclusively via the CAN bus system.

### 3.1.4 Technical Data

Power input 10-16 V DC

Consumption of LXNAV S80 at 12 V:

140 mA - minimum brightness without audio.

190 mA - maximum brightness without audio.

Consumption of LXNAV S80D at 12 V:

90 mA - minimum brightness without audio.

140 mA - maximum brightness without audio.

80 mm (3.15") standard aircraft cut-out for the LXNAV S80 indicator unit; 81x81x45mm •

Sensor box: 65x45x85mm (not including connector).

All together: 81x81x132mm (not including connector).

Weight 460g (290g for S80D)



## 4 System Description

### 4.1.1 Push Button

The two Rotary switches have a push button function. LXNAV S80 can detect short or long presses of the push button. A short press means just a click, a long press means pushing the button for more than one second.

#### 4.1.1.1 Power Button

The system is powered up using any of the push buttons or a short press of either of the rotary knobs. A long press of the upper rotary knob will turn the S80 off. Use this instead of the avionics master switch.



### 4.2 Rotary Switches

The upper rotary knob is designed for direct volume control. Short-press the upper rotary knob, then adjust volume for the Vario, Speech and Flarm beep. Long-press the upper rotary knob to shut down the system properly.

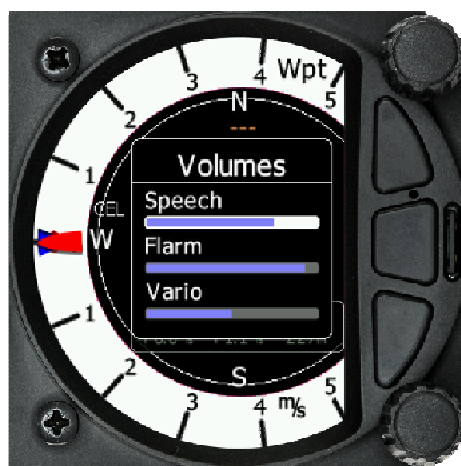

The lower rotary knob is used to adjust settings, within the current screen display or within menus. With the lower rotary pushbutton, we can toggle between MC, Bal and Bugs settings. In all other menus, this knob is used for setting values and editing texts.

The three buttons between the two rotary knobs have fixed functions. The top button is ESC (CANCEL), the middle is menu and the lower button is the ENTER (OK) button.

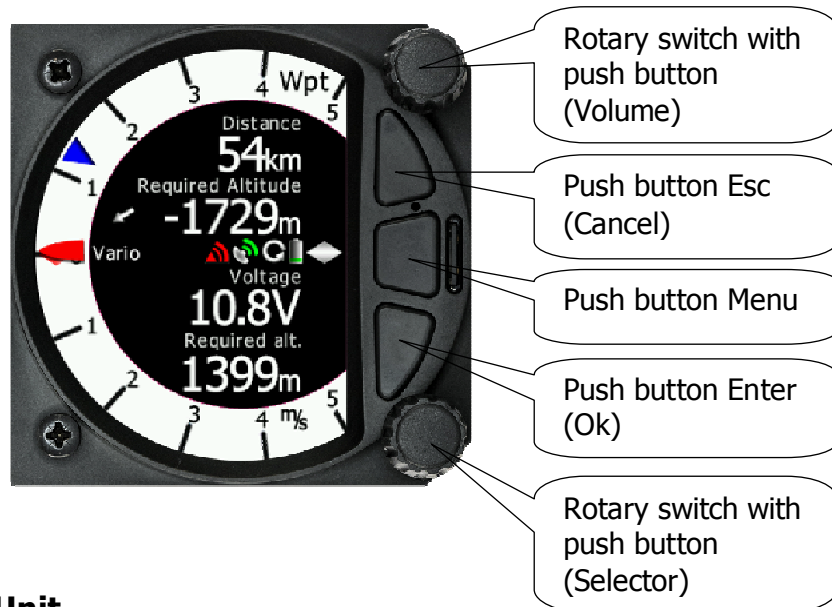

### 4.3 Switching on the Unit

A short press of any of the buttons or rotary knobs will turn on the S80. The first LXNAV welcome screen will appear with the system information (Device name, Version, Serial number...)



S80D rear seat unit cannot be powered up if the S80 is not already powered up.

When the boot procedure is completed, the setup elevation dialogue is shown.



Upper push button also has power OFF function.

## 4.4 User Input

The LXNAV S80 user interface consists of dialogues which have different input controls. They are designed to make the input of names, parameters, etc., as easy as possible. Input controls can be summarised as:

- Text editor
- Spin controls (Selection control)
- Checkboxes
- Slider control

To move the function from one control to another, rotate the lower rotary knob as follows:

- Clockwise rotation will select the next control.
- Counter clockwise rotation will select the previous control. PUSH button enters the selected feature.
- Faster rotation of the rotary knob will increase the rate at which the value changes. i.e. bigger steps in value.

### 4.4.1 Text Edit Control

The Text Editor is used to input an alphanumeric string; the picture below shows typical options when editing text/numbers. Use the bottom rotary knob to change the value at the current cursor position.



Turn the bottom rotary Knob to set the character and then press the enter key (bottom key) to move to the next character to the right. Press the escape key to move back to the left. When you have finished editing, press the Enter key. Short-press the bottom rotary knob to enter or exit an edit field ("control").

### 4.4.2 "Spin" Control

"Spin" controls are designed for numeric parameters. Rotate the knob to increase/decrease the selected value. To increase the values in larger steps, spin the bottom rotary knob faster!



#### 4.4.3 Selection Control

Selection boxes, also known as combo boxes, are used to select a value from a list of predefined values. Use the bottom rotary knob to scroll through the list.

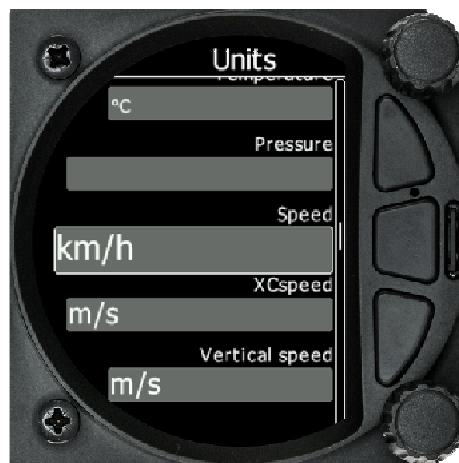

#### 4.4.4 Checkbox and Checkbox List

A checkbox enables or disables a particular parameter. Press the bottom rotary knob to toggle the value. If an option is enabled a check mark will be shown, otherwise an empty rectangle will be displayed.



#### 4.4.5 Slider selector

Some values, like volume and brightness are displayed as a slider icon

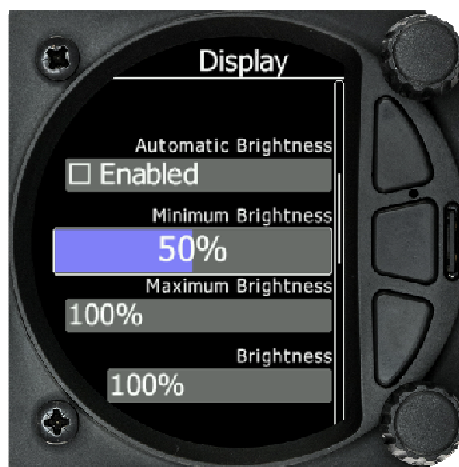

With a push of the rotary button you can activate the slide control, then with rotation of the knob you can select the preferred value and confirm it with the push button.

## 4.5 Switching off

You will lose your settings if you power down the s80 with the panel master-power switch. To archive your settings, shut down with a Long-Press of the volume (top) knob or the Shutdown option in the Settings menu.



All settings are saved during the power off procedure. We strongly recommend switching off the unit using the shutdown option in the settings menu.



If the system is powered off by the master switch, changed data will not be saved. Flight parameters at takeoff such as target altitude and position will remain in the stored memory so your final glide calculations are not affected.

## 5 Operating Modes

LXNAV S80 has five operating modes. The middle (Menu) pushbutton toggles among the 5 display modes, in a circular way. The diagram below shows the mode structure of the LXNAV S80.

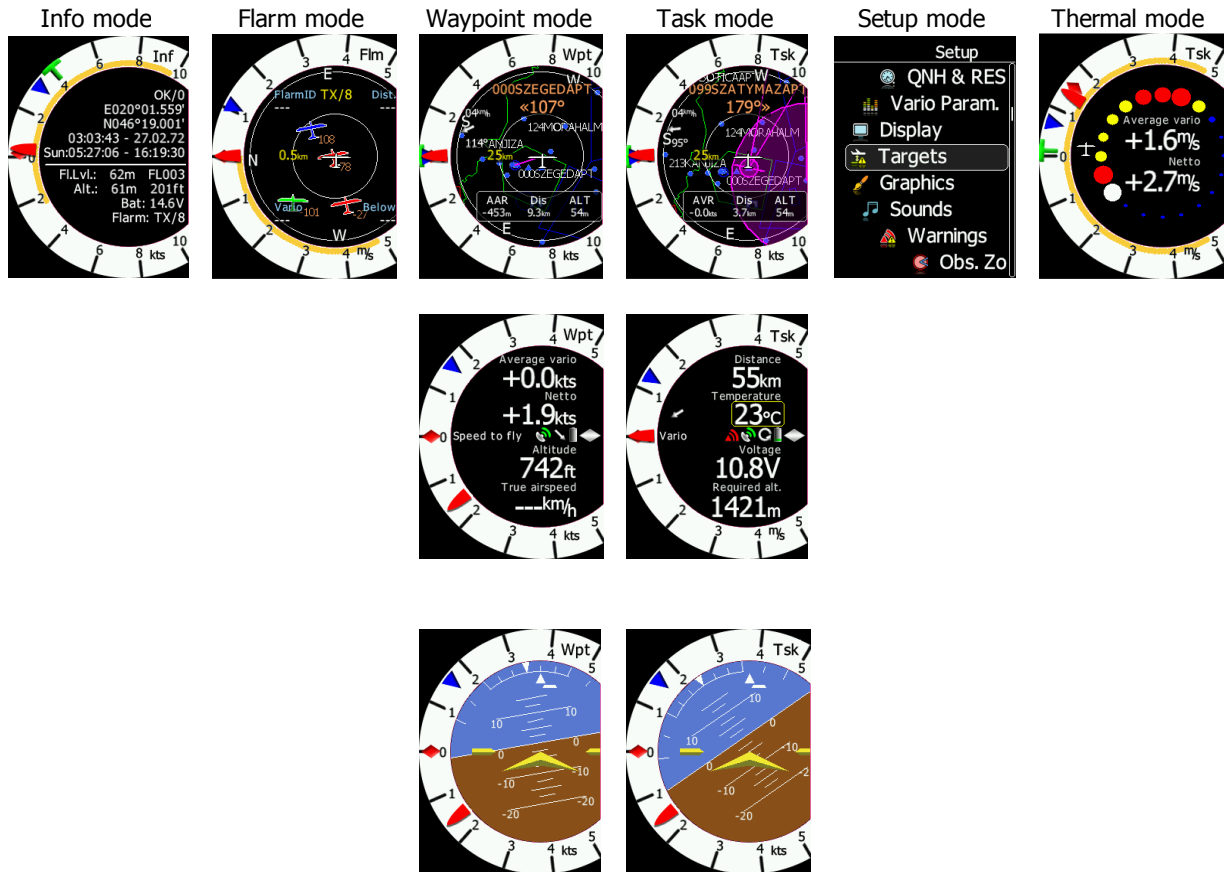

- **Info Screen:** Contains the GPS data from the GPS source Altitude and Battery voltage
- **Flarm Screen:** Showing Flarm targets in range (if a Flarm device is connected to the GPS port)
- **Waypoint screen:** Simple navigation screen to a waypoint
- **Task Screen:** Task screen showing the task and airspace
- **Setup screen:** For all aspects of the setup of the S80

## 5.1 Info Screen

The Info Screen gives you a snapshot of the GPS position, date, and time along with Flight level, altitude, Battery status, and Flarm status. Flight Level equivalent is also available in meters or feet as is the Altitude.



### 5.1.1 Quick access menu

A short press of the (lower) rotary button activates the Quick Access menu. Mc, Bugs and Bal are available.



To change the MacCready value, rotate the bottom rotary knob. A short press on the bottom rotary knob moves to the Ballast box and stores the MacCready setting. Pressing the bottom rotary knob again will open the Bugs box. If no action is performed for 3 seconds, the box will close.



## 5.2 Flarm Screen

If the S80 is connected to a Flarm source through the GPS port then the Flarm screen will display a map of relative positions of Flarm targets in range. By rotating the bottom rotary knob, you can change the range of the display from 1km to 100km



### 5.2.1 Quick access menu

A short press of the push button activates the quick access menu. Three options, Mc, Bugs and Bal are available

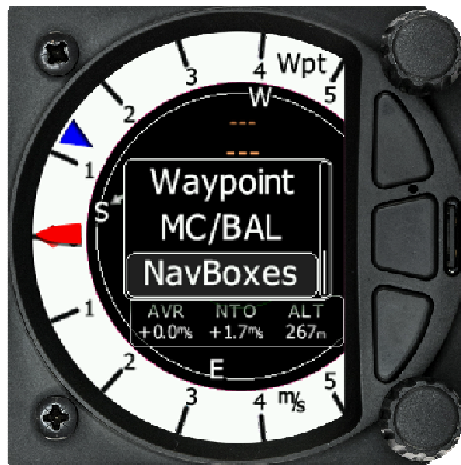

### 5.2.2 Flarm warnings

Regardless of which screen you are on, if a Flarm target triggers an urgent or important warning then the screen will change to the Flarm warning screen



The central number and chevrons indicate if the Flarm target is below or above and by how many meters/feet. The number in the bottom left indicates the range in meters/feet.

### 5.3 Waypoint Screen

The Wpt screen is a quick access screen to provide simple navigation to a Waypoint or Airport. By rotating the bottom rotary knob, you can change the range of the display from 1KM to 100Km



The first page shows a line to a selected waypoint, the name of the selected waypoint at the top of the screen and the relative bearing and chevrons indicating the direction to turn towards the selected waypoint. (The Navboxes can be configured with distance and arrival Altitude.)

### 5.3.1 Quick access menu

A short press of the menu button activates the quick access menu.



To change the MacCready value, rotate the bottom rotary knob. A short press on the bottom rotary knob moves to the Ballast box and stores the MacCready setting. Pressing the bottom rotary knob again will open the Bugs box. If no action is performed for 3 seconds, the box will close.

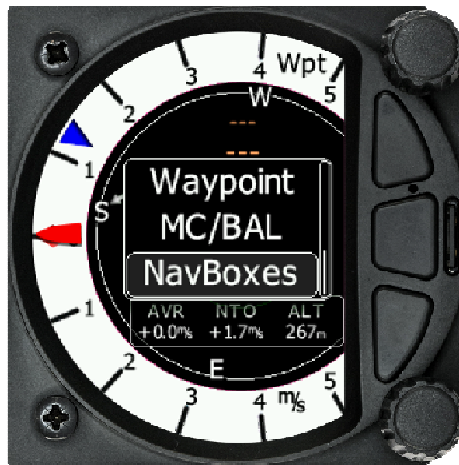

To **Select** a waypoint, rotate the bottom rotary knob to highlight the select option and then press once. This will open the Waypoint list



The Waypoint can be selected from the alphabetical list of waypoints. (See uploading files section 5.6.14.1). Rotating the bottom rotary knob moves you through the

waypoint list in alphabetical order, waypoint list in alphabetical order, clockwise increases the value, counter-clockwise decreases the value. To select the first letter of the desired waypoint, press the Enter button (bottom of the three buttons) this moves the cursor to the second letter. Rotate the bottom rotary knob until the second letter of the required Waypoint is highlighted and then press Enter. Repeat the process until the required waypoint is the only selection available. You can then either press the enter button or press the bottom rotary Knob to select the Waypoint. The screen will then change back to the navigation page and show a line to the Waypoint, Waypoint name and relative bearing.

### 5.3.1.1 Navboxes Option

Open the Quick Access menu by pressing the lower rotary knob, then select Navboxes – then press the knob to toggle the Navbox location to the bottom or right side.

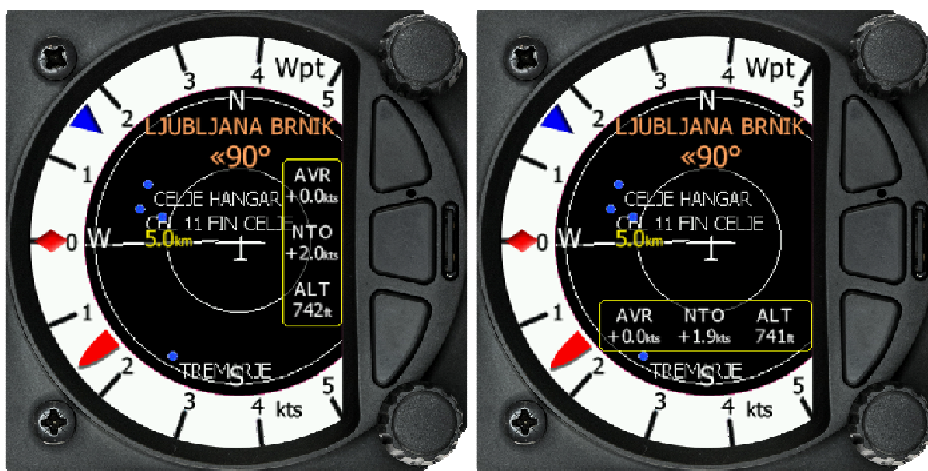

Pressing the Enter button saves the position setting and scrolls down a page.

### 5.3.1.2 Editing Navboxes

Selecting the Navboxes option and then pressing the bottom rotary Knob will allow you to select one of the three boxes by rotating the bottom rotary knob and a short press. You can then select the required data for the highlighted Navbox. A short press of the bottom rotary knob selects the desired setting and returns you to the Navbox selection. Pressing Enter at any time saves the setting and moves to the second Waypoint Page

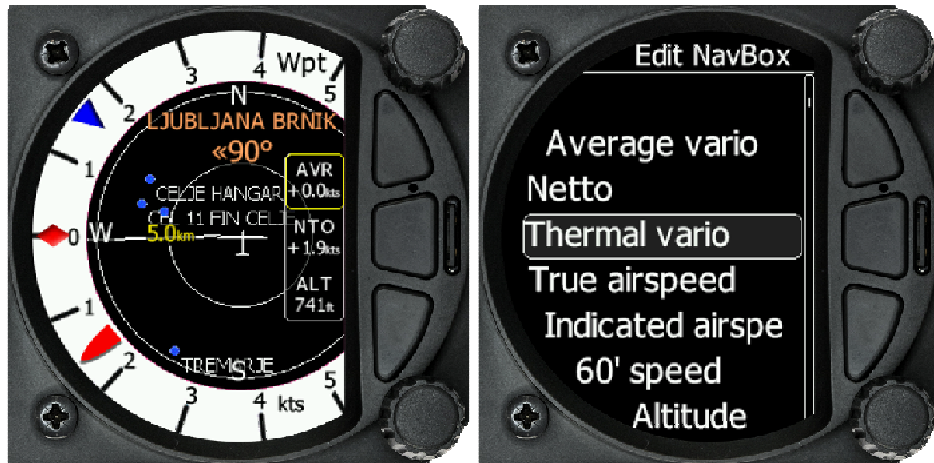

### 5.3.2 Second Waypoint Page (Numerical Data)

The Waypoint screen has a second page which contains numerical data. Defaults are Average Vario, Netto, Altitude and True Airspeed. In addition, the central line shows the status of the Flarm, GPS, Cruise/Climb and battery status. This second page can be selected by pressing the enter button once. You can return to the Waypoint navigation page by pressing the Escape button (top button of the three). For final glide, you may wish to use Arrival Altitude (above safety altitude) as one of the nav boxes.

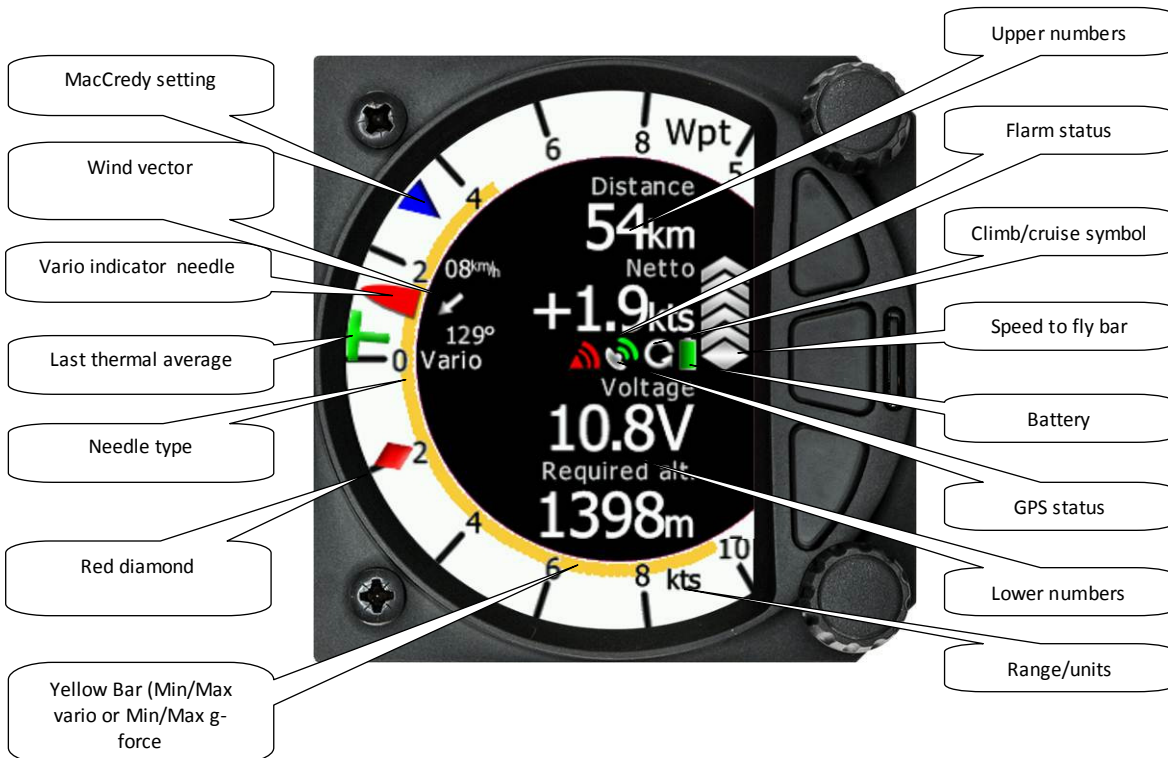

- Vario **Needle** displays the vario, netto, relative or speed to fly value. The scale can be chosen in the range of  $\pm 5$   $\pm 10$  or  $\pm 20$  (in setup, Vario Parameters). Within the software the range can be set to m/s, kts, km/h, mph or fpm (in Setup, Units, Vertical speed)
- **Upper number** displays Vario Netto, Average Vario
- **Lower number** displays True Airspeed and 60 minute task speed
- **Speed to fly bar symbol** is indicating which speed you have to fly relative to the current MacCredy setting, sink rate and speed. One arrow means 10units of speed faster or slower. Up red arrows mean fly slower and down blue arrows mean fly faster.
- **Red diamond** symbol can show netto or average vertical speed or g-force.
- **Blue arrow** symbol shows current MacCredy value.
- **Green T** symbol represents last thermal average value.
- **Yellow Bar** can show Max and Min values of vario over defined time (average vario) or G meter (over whole flight)

The numerical Navboxes can be changed using the quick Access menu with a short press of the bottom rotary knob followed by selecting Navbox from the menu and a further short press of the bottom rotary knob. With the first Navbox highlighted with a yellow border you can scroll through the four Navboxes using the bottom rotary knob. Select the Navbox you wish to change with a short press of the bottom rotary knob. This will open a list of available Navboxes.

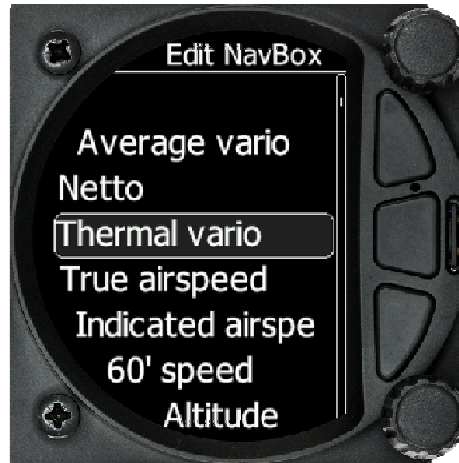

Select the required Navbox and then save this with a short press of the bottom rotary knob. Repeat the process for any other Navbox that needs to be changed.

### 5.3.3 Third Waypoint Page (AHRs)

The Waypoint screen has a third page which displays the AHRs (if this feature has been enabled See more in Ch.8.5.4)

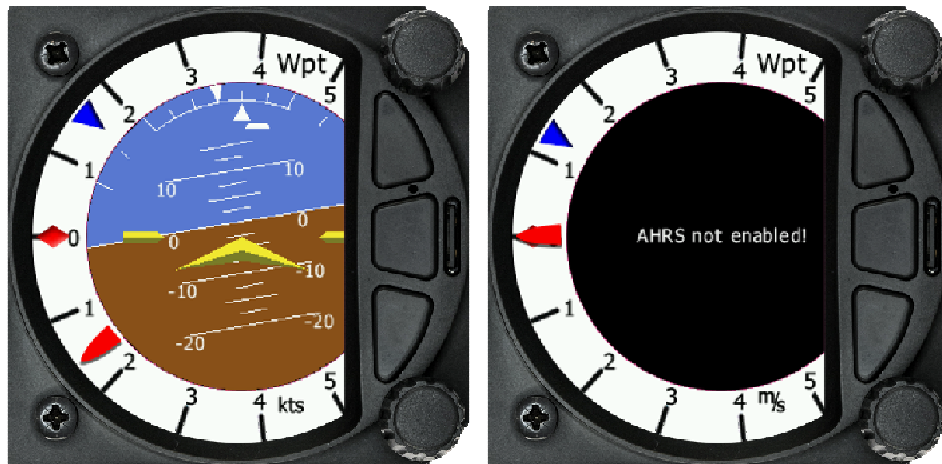

Pitch offset can be adjusted with lower rotary knob.

### 5.3.4 Quick access menu

A short press of the bottom rotary knob activates the quick access menu. In addition to changing MacCready, Ballast and Bugs you can select a waypoint. You can also change the Navboxes through this menu and "Reset the bar"



Changing the MacCready, Ballast and Bugs along with selecting a waypoint is the same as Page 1 of the Waypoint screen.

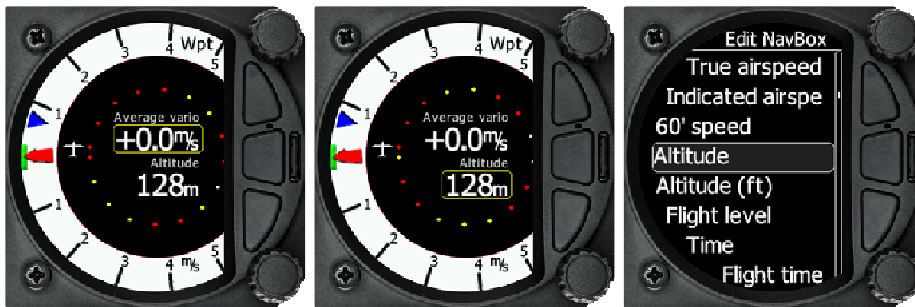

#### 5.3.4.1 Editing Navboxes

Selecting the Navboxes option and then pressing the bottom rotary Knob will allow you to select one of the two boxes by rotating the bottom rotary knob and a short press. You can then select the required data for the highlighted Navbox. A short press of the bottom rotary knob selects the desired setting and returns you to the Navbox selection. Pressing Enter at any time saves the setting and returns you to the thermaling page.

#### 5.3.4.2 Reset bar

"Rest bar" is a method of re-setting the "G" meter if configured as the yellow bar on the vario scale.



## 5.4 Task Screen

The task screen can display a navigation page including airspace and a task. By rotating the bottom rotary knob, you can change the range of the display from 1KM to 100Km



### 5.4.1 Quick access menu

A short press of the bottom rotary knob activates the quick access menu. In addition to changing MacCready, Ballast and Bugs you can Start, or Edit a task. If the Task is started you can restart or go to the next waypoint. You can also change the Navboxes through this menu.



- Selecting **start** and a short press of the bottom rotary knob will start a task.
- Selecting **restart** and a short press of the bottom rotary knob will restart the task.
- Selecting **next** and a short press of the bottom rotary knob will advance the task to the next waypoint in the task.
- Selecting **edit** task with a short press of the bottom rotary knob will enter the task editing screen. The first time you edit a task it will be blank. A short press of the bottom rotary knob will open another menu with the option to Insert, Edit, Delete or Zone. Selecting Insert will allow you to enter a waypoint from the list as a start point. Rotating the bottom rotary knob will scroll through the waypoints in alphabetical order. Pressing the Enter button will select the first letter and move the cursor to the right for the second letter. The second letter can be selected by rotating the bottom rotary knob. Repeat the process until the desired waypoint is displayed. Press the bottom rotary knob once to select it. Once the start point is selected, rotate the bottom rotary knob clockwise one click to display the second turn point. Edit the second turn point as above. Repeat for all the points in the task. When you have completed editing the task, press the page (middle) button to save the task and return to the Task navigation page.



You can also change the Observation zone from the defaults for each Waypoint. To do this, select the waypoint in the task and then press the bottom rotary knob. The quick access menu allows you to insert, edit, delete or change the zone for the Waypoint. If you select **Zone**, you can modify the zone for that specific waypoint only.

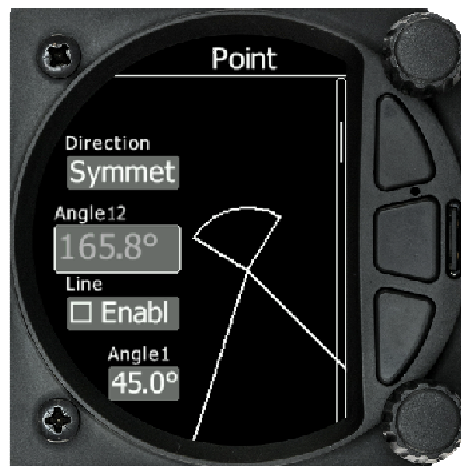

#### 5.4.2 Second Task Page (Numerical Data)

The Task screen has a second page which contains numerical data. Defaults are Average Vario, Netto, Altitude and True Airspeed. In addition, the central line shows the status of the Flarm, GPS, Cruise/Climb and battery status. This second page can be selected by pressing the enter button once. You can return to the task navigation page by pressing the Escape button (top button of the three)



The navigation boxes in this second task page can be changed using the quick access menu and selecting **Navbox**. You can make changes to the Navboxes as described in chapter **5.3.2**.

### 5.4.3 Third Task Page (AHRS)

The Waypoint screen has a third page which displays the AHRS (if this feature has been enabled See more in Ch.8.5.4)

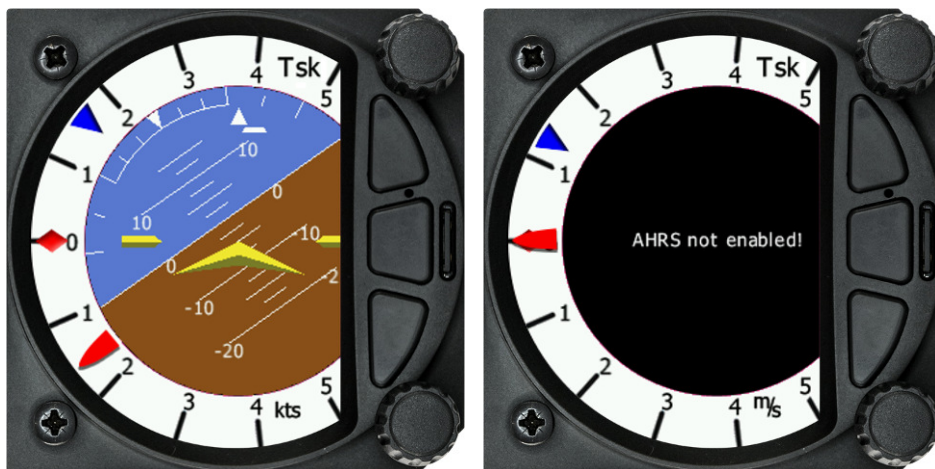

Pitch offset can be adjusted with lower rotary knob.

### 5.4.4 Quick access menu

A short press of the bottom rotary knob activates the quick access menu. In addition to changing Start, Edit Task, MacCready, Ballast and Bugs you can change the Navboxes through this menu and "Reset the bar"



Changing the Start, Edit, task, MacCready, Ballast and Bugs is the same as Page 1 of the Task screen.



#### 5.4.4.1 Editing Navboxes

Selecting the Navboxes option and then pressing the bottom rotary Knob will allow you to select one of the two boxes by rotating the bottom rotary knob and a short press. You can then select the required data for the highlighted Navbox. A short press of the bottom rotary knob selects the desired setting and returns you to the Navbox selection. Pressing Enter at any time saves the setting and returns you to the thermaling page.

#### 5.4.4.2 Reset bar

"Rest bar" is a method of re-setting the "G" meter if configured as the yellow bar on the vario scale.



## 5.5 Thermal Assistant page



The Thermaling Assistant displays a graphical representation of your location within the thermal, Large red bubbles indicate the strongest part of the thermal and small blue dots indicate the weakest part of the thermal. The point of strongest lift is indicated by a white large bubble. The Thermaling assistant can be set to automatically change to the Thermaling assistant page or be manually selected.

The two NAVBoxes within the Thermaling assistant Page can be configured using the quick access menu.

## 5.6 Setup Screen

The setup screen allows you to change the configuration and base settings for the S80 Vario.



Following items are listed in the setup menu:

- QNH &RES
- Vario Param.
- Thermaling Ast.
- Display
- Graphics

- Sounds
- Warnings
- Obs. Zones
- Units
- Hardware
- Files
- Polar & Glider
- Logbook
- Password
- About

You can scroll up and down the list of settings by rotating the bottom rotary knob and select a setting to change with a short press of the bottom rotary knob.

Some of the Options have sub menus and these are selected in the same way.



### 5.6.1 QNH & RES

Turn the bottom rotary knob to select the required entry field. Press the bottom rotary knob to select it and start editing the value. A further shot press will enter the value.



#### 5.6.1.1 QNH

This feature may be used to offset the altitude datum as the result of pressure changes during the flight. Since changing the QNH influences the indicated altitude, care should be taken when changing the value as an incorrect setting could upset the final glide calculation.

#### 5.6.1.2 Safety Altitude

This setting is the altitude reserve or safety altitude and is the height that the instrument adds to the final glide altitude required so the glider arrives over the final glide destination at the selected safety altitude. Once the safety altitude has been specified, the pilot has to keep the final glide indicator on 0 to arrive at the safety altitude. (Setup one of the Navboxes in the primary or secondary pages of waypoint or task screens to be Arrival Altitude)



## 5.6.2 Vario Param.



### 5.6.2.1 Vario needle filter

Sets a time constant of the **Vario** needle. The value can be adjusted between 0.1 and 5 s with step 1.0 s or 0.1 s. Default value is 1.5 s.

### 5.6.2.2 Vario sound filter

Sets a time constant of **Vario** sound. The value can be adjusted between 0.1 and 5 s with step 1.0 s or 0.1 s. Default value is 1.5 s.

### 5.6.2.3 Netto filter

Sets a time constant of the **Vario Netto** needle. The value can be adjusted between 0.1 and 5 s with step 1.0 s or 0.1 s. Default value is 1.5 s.

### 5.6.2.4 Relative filter

Sets a time constant of the **Vario Relative** needle. The value can be adjusted between 0.1 and 5 s with step 1.0 s or 0.1 s. Default value is 1.5 s.

### 5.6.2.5 SC filter

Sets a time constant of the **SpeedToFly** needle. The value can be adjusted between 0.1 and 5 s with step 1.0 s or 0.1 s. Default value is 1.5 s.

### 5.6.2.6 Smart Filter

Using **Smart vario filter**, vertical speed can be further filtered. Smart vario filter defines maximum speed of vario needle. "1" is the highest damping, "4" the lowest. Off means no additional filtering

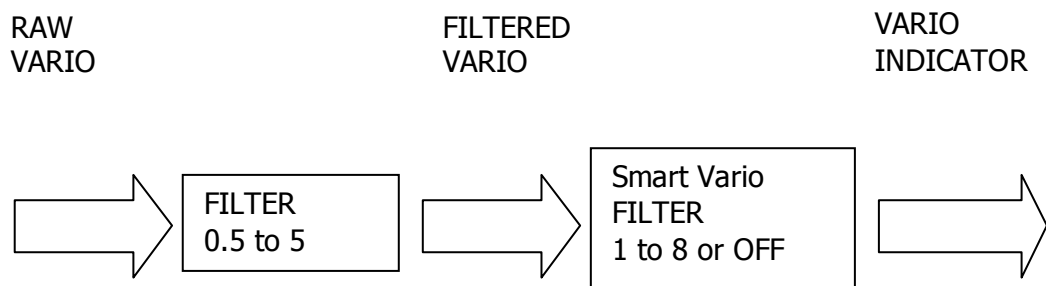

### **5.6.2.7 Needle range**

Sets full scale range of the vario (2.5 m/s, 5 m/s or 10 m/s). Default value is 5 m/s (10 kts).

### **5.6.2.8 Dead Band (SC tab)**

Defines the width of the audio dead band in speed to fly mode. Default value is  $\pm 1$  m/s.

### **5.6.2.9 Auto SC**

Defines the conditions when the instrument will switch automatically between vario and speed to fly mode.

- **OFF:** Switching is exclusively by an external switch connected to the S80.
- **GPS:** When the GPS detects that the glider is circling an automatic change over to vario will happen after approximately 10 seconds. Detection of straight flight will cause a changeover to speed command.
- **IAS:** When the IAS exceeds a pre-set value. The IAS at which switching occurs can be selected in 5 km/h steps from 100 up to 160 km/h (or the equivalent in knots or mph).
- **G-meter** – for switching between cruise and climb mode based on the G measured by the inertial system. When glider will start circling, S80 will automatically switch from cruise to climb mode.



The external switch wired to the LXNAV S80 has absolute priority and will override all other switching methods. VP (Vario priority) input can override also hard wired SC switch.

### **5.6.2.10 Vario Average Time**

Defines the integration period for the average vario in seconds. The default is 20 seconds.

### **5.6.2.11 Netto Average Time**

Defines the integration period for the average netto vario in seconds. The default is 10 seconds.

### **5.6.2.12 Temperature Offset**

The LXNAV S80 is supplied with an external outside air temperature (OAT) sensor. With the offset setting it will correct static errors of temperature measurement.

### **5.6.2.13 Inertial assisted vario**

With the LXNAV S80, it is possible to adjust the influence of g-force on the vario. This influence is very small and can be set to Off or between 0 and 4.

### 5.6.3 Thermaling Assistant



#### 5.6.3.1 Colour circles by

You have three options for the thermaling assistant, Auto Span, MacCready and Average Vario.



The colours in the thermaling assistant indicate below average (blue), average (yellow), above average (red) and strongest point of thermal (white)

If Auto Span is selected then the Thermaling Assistant will use the average performance of the last turn to calculate below, average and above average clime and indicate accordingly. If MacCready is selected then the Thermaling Assistant will use the current MacCready setting to show rate of climb below, MacCready and above the MacCready setting. If Average Vario is selected then the Thermaling Assistant will use the average vario for the flight to show rate of climb below, average vario and above average vario.

#### 5.6.3.2 Switch to thermal assistant

With this box ticked the S80 will change to the Thermaling Assistant screen when the glider starts turning in a climb. If the box is left un-ticked then the thermaling assistant page can be accessed manually in Waypoint or Task mode on page 4.



The S80 will only detect turning if a GPS or Flarm device is attached. The S80 uses a combination of change of speed, angle of bank and direction change to indicate circling.

## 5.6.4 Display

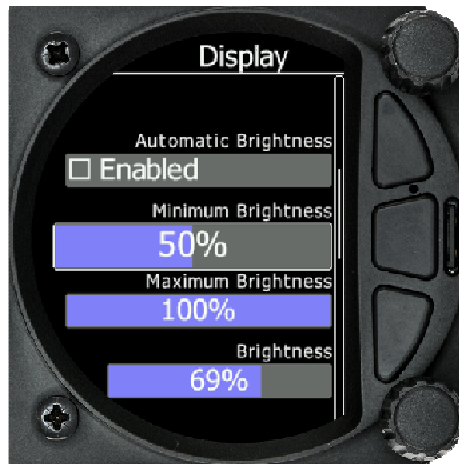

### 5.6.4.1 Automatic Brightness

If the Automatic Brightness is checked then the brightness will be automatically adjusted between the minimum and maximum parameters set. If the Automatic Brightness is Unchecked then the brightness is controlled by the brightness setting

### 5.6.4.2 Minimum Brightness

Use this slider to adjust the minimum brightness for the Automatic Brightness option.

### 5.6.4.3 Maximum Brightness

Use this slider to adjust the maximum brightness for the Automatic Brightness option

### 5.6.4.4 Brightness

- With the Automatic Brightness unchecked, you can set the brightness manually with this slider.

### 5.6.5 Graphics

The graphics option has a sub menu for Flarm and for Airspace and Tasks



#### 5.6.5.1 Graphics – Flarm



#### 5.6.5.2 Colours can be set for the following:

- Glider Above Colour
- Glider Below Colour
- Glider Near Colour
- Selected target Colour

#### 5.6.5.3 Label Text

This option can be set to None, Flarm ID, Climb rate, Relative vertical

**5.6.5.4 Active Timeout**

Adjusts the time a glider symbol remains on the map after it has last been seen by the Flarm.

**5.6.5.5 Inactive Timeout**

Adjusts the time of inactive gliders on the Flarm target list. Inactive gliders are gliders, where the Flarm signal has been lost after Active timeout. The targets became inactive and remain only on the Flarm target list for this time.

**5.6.5.6 Draw Line to selected Target**

Checkbox to enable or disable a line drawn to a selected Flarm target or not.

**5.6.5.7 Draw History**

Select if a trail is drawn behind Flarm targets to show where the targets have been

**5.6.5.8 Plane icon size**

To adjust the pixel size of Flarm targets.

**5.6.5.9 Graphics – Airsp. & Tsk.**

In this dialogue you can define the airspace map presentation. Check the **Show airspace** item to enable airspace displays in navigational pages. If this item is unchecked no airspace will be displayed.

Use **Show only airspace below** to eliminate airspace which is going to be too high for the day. For example, if the forecasted cloud base is to be 1500 m, set this value to 1600 m and your screen will be much more readable.

For the task settings, you can turn on the display of waypoints with the check box and change the colour of the task, the line to the next waypoint and the zone colour. In addition, you can change the transparency of the Observation zone, user messages and the Navboxes. Zone line width can also be adjusted.

In the airspace type list you can specify how each airspace type is displayed. You should define each type of airspace zone separately. First choose an airspace type from the list. You can modify the **Transparency** of the selected type. **Zoom** value defines to which zoom

level this type is going to be visible. The **Colour** and **Width** items specify how selected airspace zone will be drawn.

### 5.6.6 Sounds

The sound option has a sub menu for Equaliser, vario and Flarm



#### 5.6.6.1 Equalizer Option

With the bottom rotary knob you can adjust the volume for each frequency. Settings are stored when you exit the screen

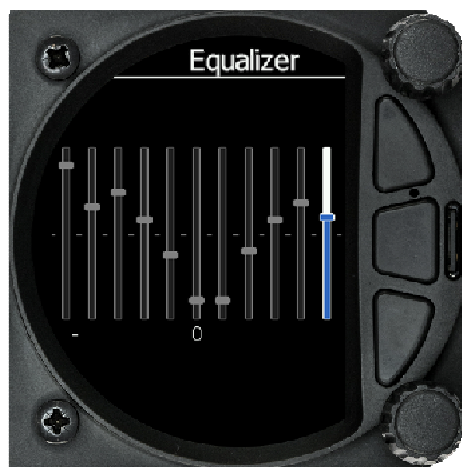



### 5.6.6.2 Vario Sounds



Vario Volume default setting can be set with this slider.



The volume for Vario, Flarm and Speech can also be adjusted directly with the top rotary knob whilst in the Flarm, Waypoint and Task screens

#### 5.6.6.2.1.1 Vario Audio mode

Vario audio mode has the following options:

- **Linear positive:** sound is interrupted with silence every few milliseconds when the needle is positive; on negative side sound is linear (not interrupted).
- **Linear negative:** inverse function to **Linear positive**.
- **Linear:** sound is linear and non-interrupted in full scale range.
- **Digital positive:** similar to **Linear positive**, except frequency is not changing linearly but with larger steps.
- **Digital negative:** inverse function to **Digital positive**.
- **Linear positive only:** sound is present only at positive values, for negative values there is silence.
- **Digital positive only:** similar function to **Linear positive only**, except the sound is similar to the digital tone.

#### 5.6.6.2.1.2 SC Audio mode

SC audio mode has five modes:

- **Netto Speed:** Sound follows netto value.
- **SC Mixed:** for positive relative values the sound represents relative; for negative relative values the sound represents SC (for that setting it is recommended to set SC needle to relative). Dead band is active only for negative values.
- **Speed to Fly:** sound is linear and non-interrupted in full scale range.
- **SC negative:** inverse function to SC positive.
- **SC positive:** sound is interrupted with silence every few milliseconds when the needle is positive; on negative side sound is linear (not interrupted).

#### 5.6.6.2.1.3 Audio frequencies

- **Freq at 0%** defines the tone frequency at 0 m/s.
- **Freq at +100%** defines the tone frequency at full + deflection.
- **Freq at -100%** defines the tone frequency at full – deflection.

#### 5.6.6.2.1.4 Equalization preset

We have three options: default LXNAV speaker, flat setting or user defined.

#### 5.6.6.2.1.5 Thermal Assistant

Is a system generated sound which is different from other vario sounds. This sound helps the pilot in a thermal by interrupting other varios sounds a few seconds before the thermal reaches its maximum lift. The pilot can set how many seconds before thermal maximum or disable the feature.

#### 5.6.6.2.1.6 Speech Volume

With the Speech volume slider the volume of voice warnings can be changed.



The volume for Vario, Flarm and Speech can also be adjusted directly with the top rotary knob whilst in the Flarm, Waypoint and Task screens

#### 5.6.6.3 Flarm Sounds



**Flarm Volume:** can be adjusted with the slider

**Flarm Low Alarm:** For distant Flarm targets the S80 can give a short or long message, just a beep or be turned off.

**Flarm Important Alarm:** For close Flarm targets the S80 can give a short or long message, just a beep or be turned off.

**Flarm Urgent Alarm:** For very close Flarm targets the S80 can give a short or long message, just a beep or be turned off.



The volume for Vario, Flarm and Speech can also be adjusted directly with the top rotary knob whilst in the Flarm, Waypoint and Task screens

### 5.6.7 Warnings

Warnings can be enabled or disabled in this section.



The warnings dismiss time can be set from 0 to 120 seconds

Dismiss while circling: This dismisses Flarm alarms whilst circling for Flarm targets in the same thermal. Flarm warning for urgent alerts over ride this.

Altitude Alarm: can be set in meters/feet

Altitude Alarm time out: can be set from 10 to 500 seconds

### 5.6.8 Obs. Zones

The default Observation Zones can be configured in this section for all tasks.



The start, turn point and Finish zone can be configured separately although the setup is very similar.

The Start and Finish zone do not have the option of the AAT check box or Auto next.

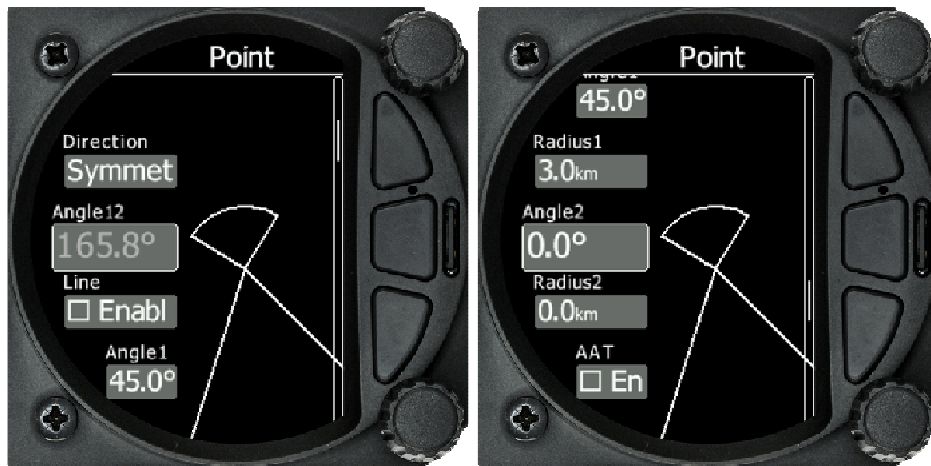

- Direction:** Options include Start, Previous, Next, Symmetrical or Fixed angle
- Angle 12:** is greyed out unless fixed angle is specified in Direction
- Line Check Box;** typically used for start and Finish. If line is checked then Angle 1, Angle 2 and Radius 2 are greyed out
- Angle 1:** Sets the angle of the Turn Point Zone
- Radius 1:** Sets the radius of the Turn Point Zone
- Angle 2:** Sets angle 2 for complex Turn Points and Assigned Area Tasks
- Radius 2:** Sets the radius for complex Turn Points and Assigned area Tasks
- AAT Check Box:** when checked, the S80 considers the area created within the zone as an Assigned area
- Auto Next:** Typically used in racing tasks, will set the navigation of the S80 to the next turn point when a single point is made within the Turn Point Zone.

### 5.6.9 Units

Use this menu to specify units, UTC time offset and type of ballast input.



- Language:** Available in later versions
- Distance:** Units available; Miles, Nautical Miles, Kilometres,
- Altitude:** Units available Feet, meters
- Temperature:** Units available; Degrees Centigrade or degrees Fahrenheit
- Pressure:** Units available; Inches of Mercury, mm of mercury, mbar,
- Speed:** Units available; fpm, m/s, mph, kts, km/h

**XC Speed:** Units available; fpm, m/s, mph, kts, km/h

**Vertical Speed:** Units available; fpm, m/s, mph, kts, km/h

**Wind:** Units available; fpm, m/s, mph, kts, km/h

**Weight:** Lbs or Kg

**Load:** Lb/ft2 or Kg/m2

**Longitude/Latitude:** DD.ddddd, DDMM.mmmmm', DDMM'SS.ss", DD.dddd, DDMM.mmm', DDMM'SS"

**UTC Offset:** in half or whole hours plus or minus Zulu

**Ballast:** weight, Load, overload

### 5.6.10 Hardware

The hardware setup has a sub menu for Vario, Indicator, comms. and Battery



#### 5.6.10.1 Vario Setup



## TE compensation

The LXNAV S80 offers two methods of vario Total Energy Compensation:

- Pneumatic TE Pitot tube
- Electronic TE compensation



It is important to note that the method of TE compensation is set up when the instrument is installed by virtue of the pneumatic connections made to the TE and static ports. Changing the compensation type in the setup screen below WILL NOT change the method of compensation - the pneumatic plumbing has to be changed first.



If the TE pitot tube has been connected TE compensation should be set to 0%. There is no further adjustment of TE compensation possible. Quality of the TE tube is the one and **only** factor.



For **electronic** TE compensation, connect the TE port to *static*. Set the Vario Param TE compensation **initially** to 100%, then adjust this with flight testing, described below.

The electronic TE compensation can be fine-tuned during flight using the following procedure: it is essential that this is only done in smooth air; it is not possible to tune the TE accurately in turbulent air.

Set TE compensation to 100%. Accelerate up to approximately 160 km/h (75 kts) and keep the speed stable for a few seconds. Gently reduce the speed to 80 km/h (45 kts). Observe the vario indicator during the manoeuvre. At 160 km/h the vario will indicate about  $-2$  m/s ( $-4$  kts). During the speed reduction the vario should move towards zero and should never exceed zero (slightly positive indications are acceptable). If the vario shows a climb the compensation is too low; increase the TE%; and vice versa. Try another "zoom" to assess the change and make further adjustments if necessary.

Electronic TE compensation is only effective when the Pitot tube and static sources are co-located and the pneumatic lines to the instrument are approximately the same length. The best sensor to use is the combined pitot/static Prandtl tube. If problems are experienced with the electronic TE compensation the most likely cause is the glider's static source. The static source can be checked by plumbing the pneumatic tubes for electronic compensation and then setting the TE: to 0%. In still air accelerate to approximately 160 km/h (75kts) and slowly reduce the speed to 80km/h (45kts). Observe the vario indicator. If the static source is good the vario should immediately start to move to show a climb. If the needle firstly shows increased sink and then moves to a climb, the static source of the glider is unsuitable and there is no way to provide successful TE compensation electronically. The use of a dedicated and accurate fin-mounted pitot/static source such as a Prandtl tube might help.

## SC switch

The LXNAV S80 has an input for an external **speed command switch**. Using the external switch it is possible to switch between SC and Vario manually. Setting the **SC switch** to **ON** means that closing the switch will cause the instrument to enter SC mode. Setting SC switch to **OFF** means that closing the switch will select Vario mode. There is a third option by setting SC INPUT to **TASTER** and connecting a push button to the input; each key press will

toggle between SC and Vario (mandatory setting for LX Remote, which has provided push button for SC).



There is another input called VARIO PRIORITY. When this input is activated by grounding the appropriate wire the unit will change over to Vario immediately. This input wire is set open (not grounded) as a factory default on delivery. This switch has priority over all SC switching methods. This input is not wired in standard wiring, but it must be wired by customer.

### Digital Input 0 and 1

The LXNAV S80 has two external digital inputs which can be set to indicate gear, airbrakes and water open or closed. Wiring is described in Ch. 8.6.2 Wiring. For In0 and In1 are used pin 8 and pin 4 on SUBD15.



Input pins are available on rear DB15 connector, but they are not wired.



Input is will be active when it is short on ground.

### 5.6.11 Indicator setup

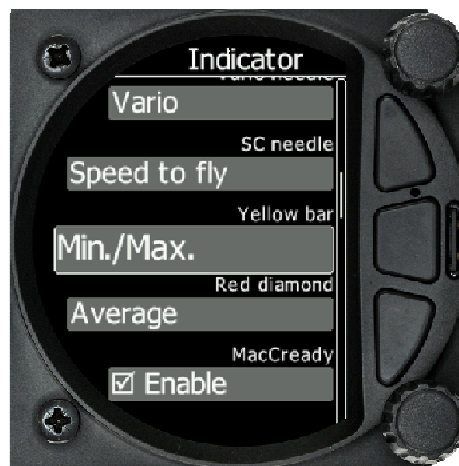

Vario Needle: Can be set to Relative, Netto, Speed to Fly or Vario

SC needle: Can be set to Relative, Netto, Speed to Fly or Vario

Yellow Bar: Can be set to G-meter, Min/Max vario or no bar

Red Diamond: Can be set to G-meter, Netto, Average vario, or No diamond

MacCready: Can be enabled or disabled

Thermal: can be enabled or disabled

STF of Speed To Fly: Can be enabled or disabled

Flarm: Can be enabled or disabled for warnings on the Vario Indicator

### 5.6.12 Comms. Setup

Used to configure the two ports on the back of the S80 for connection to a GPS/Flarm source and to a PDA



Each port can be configured separately. If your PDA device does not support automatic switch to DIRECT LINK between GPS and PDA port, here is manual **GPS-PDA link** menu. When **autobaudrate** is enabled, the LXNAV S80 will automatically search on all speeds to receive valid data. When the S80 receives a valid NMEA sentence it will lock on that baudrate and stop searching. In case that communication is lost LXNAV S80 will start again searching on all baudrates.



Baudrate on PDA must not be lower than the setting on GPS port



To get better performance of LXNAV S80 it is recommended that both baudrates be set as high as possible.

**NMEA output** on PDA port can be enabled or disabled. If you are not using a PDA port, this setting should be disabled.

### Beeps requested from PDA

If a PDA is connected to the S80 the PDA is able to send a beep command to the S80, if that feature is enabled, S80 will beep on PDA request.

### 5.6.13 Battery Chemistry Setup

A new feature within the S80 is the ability to configure your battery chemistry and battery warnings.





Batteries used in gliders today are not just the old style lead acid battery but also Lithium IIon (LiIon) and Lithium Iron Phosphate (LiFePo). Each battery type has a different power delivery curve and it is now possible to configure the Low and High Battery warnings

Select Battery from List gives you a drop down list with the suggested battery settings for Full Voltage, Low Battery Voltage and Empty Voltage as pre-sets. Selecting one of these will set the values in the following boxes.



Alternatively you can manually change the Full Voltage, Low Battery Voltage and Empty Voltage if your battery type is not listed.

### 5.6.14 Files

The Files menu allows you to upload or select Waypoint, Airspace and Flarm Net files.



#### 5.6.14.1 Waypoints File

Selecting the Waypoints option opens a list of .cup files available on the SD card or in the internal memory. Selecting a file loads this file for use.



Please note that only one Turn Point file can be loaded at any one time.

### 5.6.14.2 Airspace File

Selecting the Airspace option opens a list of .cub files available on the SD card or in the internal memory.



Selecting a file loads this file for use.

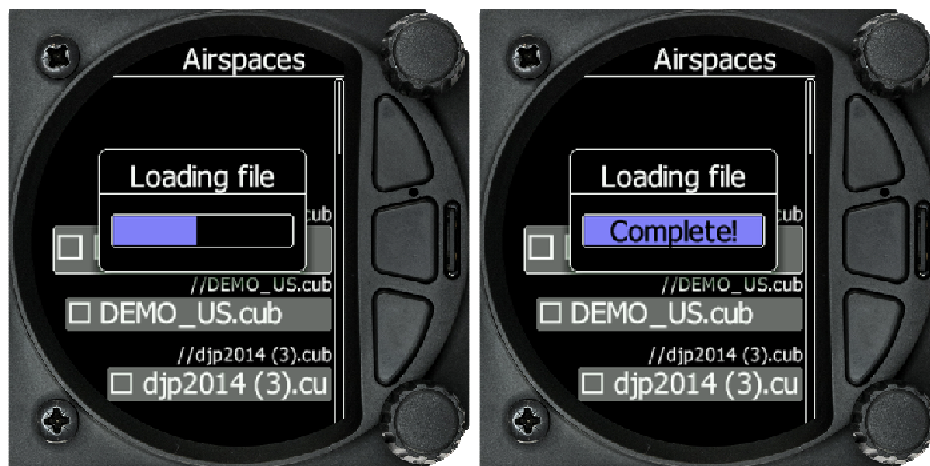

Please note that only one Airspace file can be loaded at any one time.

### 5.6.14.3 Flarmnet File

Selecting the Flarmnet option opens a list of .fln files available on the SD card or in the internal memory. Selecting a file loads this file for use.



Please note that only one Flarmnet file can be loaded at any one time.

### 5.6.15 Polar and Glider

The Polar and Glider section allows you to load and edit a set of parameters for your gliders Polar. You can select from a pre-defined list of nearly every common Glider or make your own Polar.



**Select Glider from List:** Presents you with an alphabetical list of all the common gliders and associated Polar data. All glider data will be copied from the chosen polar. Check the best glide ratio and minimum sink rate displayed. To see whether the polar data matches your glider's performance, review the MacCready Setting Menu. Ch.5.3.1



You can modify the polar by changing coefficients **a**, **b** and **c**. A polar is defined as a quadratic equation with the parameters a, b, and c. Use the SeeYou program (Tools->Polar) to calculate coefficients a, b and c for a given glider's polar. The program requires three sink points entered at selected speeds (e.g.: 100 km/h, 130 km/h, and 150 km/h). The program will calculate the values of a, b and c, which should be noted and entered into the LXNAV S80.

**Class:** Options for Touring, Ultralight, World, Doubleseater, Club, 18-meter, 15-meter, Open, Standard, and Unknown are available.

**a, b, c:** Options can be adjusted or entered for a non-listed glider.

**Stall speed** is used to generate stall warnings which are available with integrated Voice module.

**Reference load** (wing loading) value represents the value at which the polar was measured.

**Reference weight** corresponds to the weight value at which the polar was measured.

**Maximum takeoff .weight** is the maximum take-off weight allowed for the glider. It is not used in the calculation; it is just a reminder to the pilot of the maximum take-off weight.

**Empty** weight is weight of the glider without the pilot and ballast.

**Empty glider weight** is a weight of empty glider. This number can be found in a glider book.

**Pilot weight** is the weight of the pilot with parachute and baggage.

**Co Pilot Weight** is the weight of the co-pilot with parachute and baggage.



$$\text{overload} = \frac{\text{Empty.glider.weight} + \text{Pilot.weight} + \text{Water.ballast}}{\text{Minimum.glider.weight}}$$

### 5.6.16 Logbook

The logbook page lists all of the flights in date order.



If GPS data is present the logbook will show present date and time of departure. Manual navigation (without GPS) will show duration and will be marked with “—” marks.



### 5.6.17 Password

There are several system passwords which run specific procedures as listed below:



#### 5.6.17.1 List of Password functions

DEBUG_INFORMATION_PASSWORD	90000
RESET_TO_FACTORY_DEFAULT_PASSWORD	00666
UPDATE_DEVICES_PASSWORD	89891
ENTER_AHRS_LICENSE	30000

### 5.6.18 About

In the about page, information about the display platform and the vario platform can be found:

**Display platform:** Application version, serial No, Hardware version,

**Vario platform:**, Application version, serial No, Hardware version



## 6 Variometer and Altimeter

All signals from the pneumatic sensors (altitude, speed) are derived from high quality pressure sensors, which mean that no flask is necessary. The vario signal is derived from the altitude signal. All signals are temperature and altitude compensated. The colour display shows the vario information as well as many other parameters.

The display is user configurable. The Variometer can be configured to show:

- **Range** 5, 10 and 2.5 m/s or 10, 20 and 5 kts.
- **Time constants** 0.1 s to 5 s, in addition there are 4 settings for electronic processing for the vario signal.
- **Netto** shows the air mass lift and sink.
- **Relative** shows the lift or sink that would be achieved if the glider was circling at the thermaling speed.

There are two ways by which the vario indications can be corrected for total energy. Electronic TE compensation based on speed changes with time and pneumatic compensation with a TE probe. The quality of the TE compensation depends entirely on the location, size and dimension of the TE tube. The installation must be leak-proof.



If an electronic TE compensation is selected the TE ( $P_{st}$ ) port should be connected to a good static pressure source. If pneumatic compensation is selected the TE ( $P_{st}$ ) port should be connected to the TE probe.

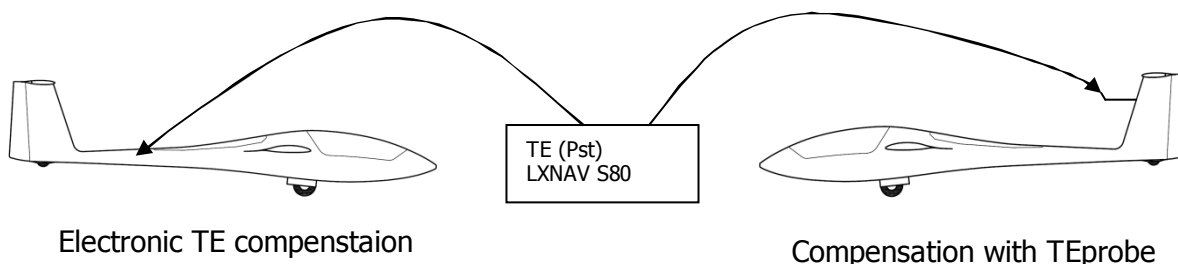

### 6.1 Altimeter

The altimeter of the LXNAV S80 is temperature compensated from  $-20^{\circ}\text{C}$  up to  $+60^{\circ}\text{C}$ . The altimeter is calibrated up to 20000 m.

### 6.2 Speed Command

Speed command flying based on the MacCready theory is a very useful tool to optimise cross-country speed. When the instrument changes to speed command mode the audio will change and become a director informing the pilot whether he is flying too fast or too slow. In order to reduce confusion between vario and speed command audio some special features are incorporated

- Continuous audio signal in + possible (other kinds of signals can be chosen, see setup).
- No audio at correct speed (dead band).



## 7 Flying with the LXNAV S80

To get the best out of the LXNAV S80 it is important that some preparation is done prior to take-off. Trying to configure the instrument or set a task while flying is very hazardous especially in a competition. Pre-flight preparation will ensure that the flight will be both safe and enjoyable.

### 7.1 On the Ground

#### 7.1.1 Power on Procedure

Press any of the rotary or push buttons to start the LXNAV S80. The LXNAV S80 welcome screen will appear. The first screen shows the version of the boot loader, firmware, hardware and serial number. The boot procedure normally takes a few seconds. When completed, the Set Elevation dialogue is shown.

#### 7.1.2 Set Elevation and QNH

This setting is crucial for final glide calculation: therefore please pay careful attention to it.



The instrument will offer elevation over standard pressure level QNE. Use the knob to fine-tune the elevation.

The **QNH** should be changed only when airfield elevation and QNH pressure are given. This might happen in some competitions.

In all other cases the elevation should always match QNH pressure.



The Set Elevation dialogues are not shown if the LXNAV S80 is switched off and on during flight.



QNH can be also corrected during flight under Setup-QNH and RES menu.

### 7.1.3 Pre-flight Check

After elevation setup the LXNAV S80 will switch to the Info screen for normal operation mode.

Use the middle (Menu) button to scroll to Flarm, Waypoint or Task Screen to verify that the MacCready, Ballast, and Bugs settings are set to the expected values for the current flight.

In any of these screens, press the bottom rotary button to raise the dialogue box to check or set MacCready, Ballast, and Bugs values.



Rotate the bottom knob to modify any setting. Next, check the safety altitude (height above destination, arrival altitude) setting.

Refer to 5.6.1.2 to find out how to define the safety altitude.

## 7.2 Airborne

### 7.2.1 Final glide calculation

Final glide is a function calculated from the target distance, target elevation, altitude, wind component, MC setting and Bug setting. The S80 will have enough information to calculate this automatically as long as a GPS source is attached and the target to navigate to is set in Waypoint or Task screen. To display the Arrival Altitude (above Safety Altitude) make sure you have configured at least one of the nav boxes on the primary or secondary screens to Arrival Altitude.

## 8 Installation

The LXNAV S80 requires a standard 80 mm cut-out.

Three pressure connectors are fitted to the back of the S80. A label shows their functions.

- $P_{\text{static}}$  means static pressure connector.
- $P_{\text{total}}$  means pitot or total pressure connector.
- TE means total energy TE pressure connector.

If the unit is to be configured for electronic TE compensation the connections are as follows:

- $P_{\text{static}}$  Static
- $P_{\text{total}}$  Pitot or Total pressure
- TE/ $P_{\text{static}}$  Static

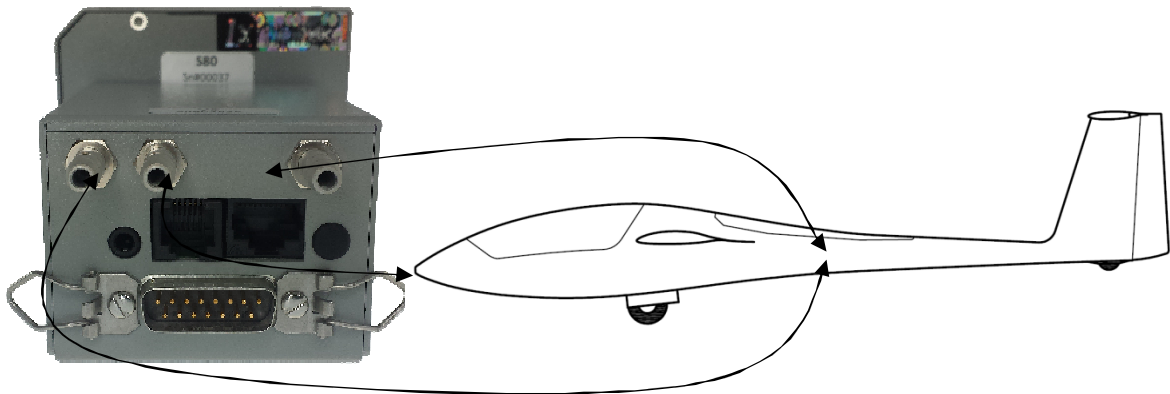

If the unit is to be configured for pneumatic TE compensation using a TE tube, then the connections are:

- TE/ $P_{\text{static}}$  TE tube
- $P_{\text{static}}$  Static
- $P_{\text{total}}$  Pitot or Total pressure

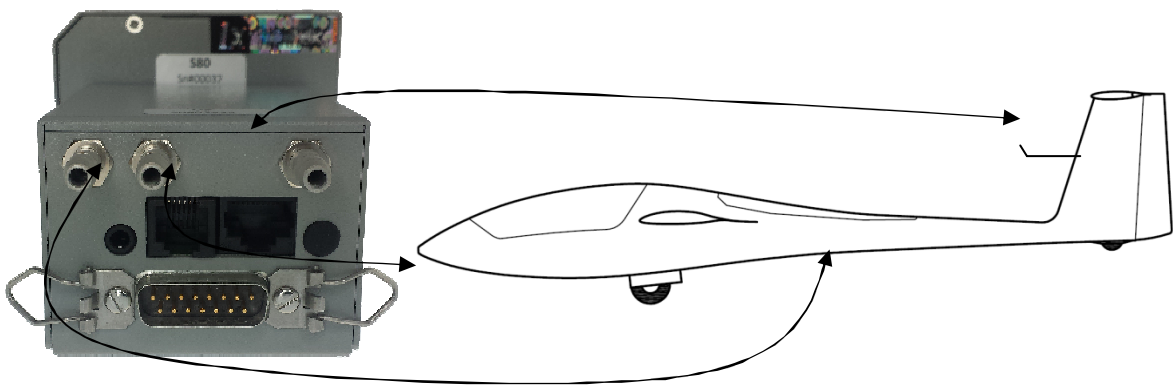

If the  $P_{\text{total}}$  and Static are connected the wrong way around there will be no integrator (average climb) and speed to fly indication during the flight.

The LXNAV S80 is connected to 12 Volt power via the 15-pin SUB-D connector. Optionally LXNAV S80D can be connected via the CAN bus and the connectors are labelled with "CAN" at each end.



Instrument has no internal fuse. **3A external fuse is required!** Power supply cables should use a minimum of 0.5 mm<sup>2</sup> wires.

## 8.1 Installing the LXNAV S80

The LXNAV S80 vario should be mounted in a standard 80 mm hole.

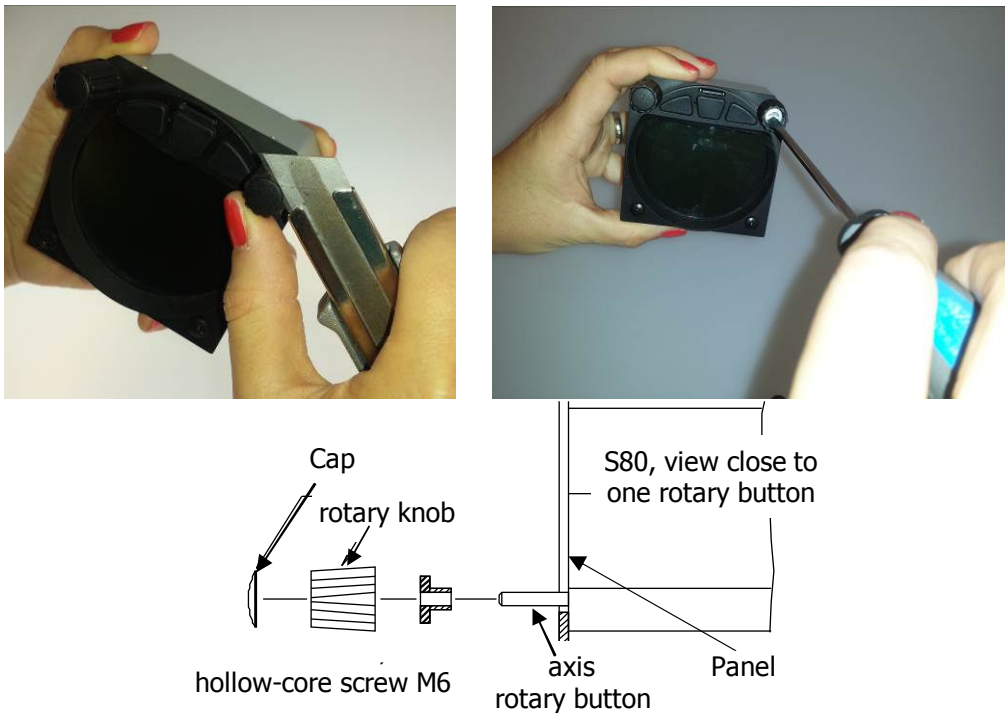

Remove the two rotary knob caps with a knife or flat screw driver, then hold each knob and unscrew it.

Remove the remaining two screws and the two M6 threaded nuts. Install S80 into the panel, screw back all screws, nuts and knobs. Make sure that between the knobs and the panel there is some space, to push button.



Be sure that LXNAV S80 is placed far enough from compass.

## 8.2 Connecting LXNAV S80

LXNAV S80 is connected to 12V DC power supply. Red wire goes to + positive and blue wire goes to – ground. If you don't use S80D (second seat unit) The Can connector should be left terminated with a CAN terminator. The SC cable is used for external switch, for switching between climb and cruise mode.

### 8.3 Cutout of S80



Length of screw is limited to max 4mm!

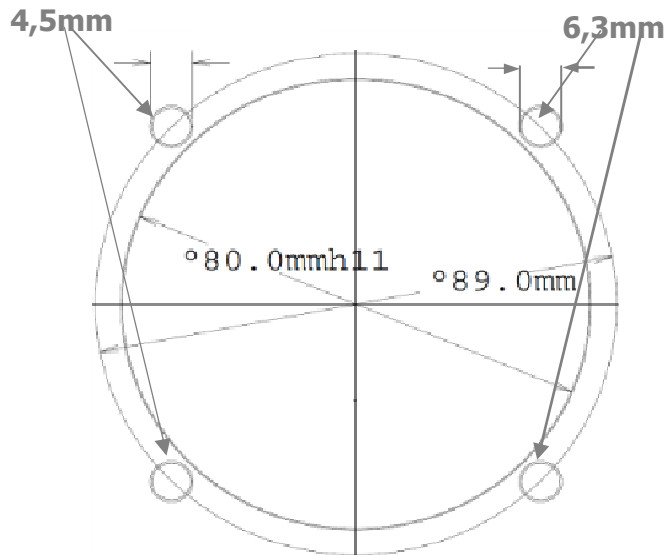
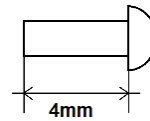

### 8.4 Available cables for GPS and PDA ports

GPS port

Device	Cable code
Nano power	CC-NP-LX (RX/TX are crossed)
Generic RS232 with female DB9	V7-GPS-232
Flight recorders, FLARMS with standard 6p IGC connector RJ11 type, Red Box, Colibri, Colibri2, VL	V7-GPS-IGC
Power flarm (RJ45), K6 mux	V7-GPS-PF
Power flarm Core	V7-GPS-PFCORE

PDA port

Device	Cable code
OU DIE	CC-NP-OU DIE1
Generic RS232 with female DB9	CC-NP-232
IPAQ 310/314	CC-NP-IPAQ310
IPAQ 38/39xx/47xx	CC-NP-38
MiniMap	CC-NP-LX
Butterfly Connect	CC-NP-BFC



PDA and GPS are not designed in accordance with IGC standard. It can be used only with dedicated cable. Do not plug unknown cable to it as it may damage LXNAV S80 unit.

## 8.5 Installation of options

The LXNAV S80 can be optionally connected to a 2<sup>nd</sup> seat repeater unit LXNAV S80D, remote stick, magnetic compass and AHRS option.

### 8.5.1 S80D option (S80 repeater)



In two-seat gliders it is possible to install the LXNAV S80D rear seat device. The S80D looks almost identical to the S80. In fact it runs on exactly the same software as on first seat device.

The basic idea of the two-seat configuration is that both devices work independently from each other with the possibility of automatically exchanging various pieces of data (volume, Mc, polar...).

#### 8.5.1.1 Data Exchange

All data is exchanged between front and rear unit. LXNAV S80 also exchanges data with GPS and PDA. Change of MC, Bal, Bugs, Volume, polar settings,... on PDA, will also influence on LXNAV S80. The Same will happen also in opposite way.

#### 8.5.1.2 Cable Wiring (LXNAV S80D)



### 8.5.2 Magnetic compass (Compass -CAN)



Is simply connected to CAN bus, main unit will recognize it. This option is not released yet but is planned for a future software release.

### 8.5.3 Remote stick (Remote-CAN)



Remote stick is also connected to CAN bus. On S80 is provided special menu to register remote stick. Device must be registered in case of double seat device, there is possible to have two remote stick, one registered on front and another on rear device.

### 8.5.4 AHRS option

To activate AHRS, an activation code must be purchased.

AHRS option can be activated by the following procedure:

- Enter password 30000
- Enter 13-digit license key and confirm

If the code is correct, you will see an AHRS on AHRS page.



## 8.6 Ports and Wiring

### 8.6.1 LXNAV S80 ports

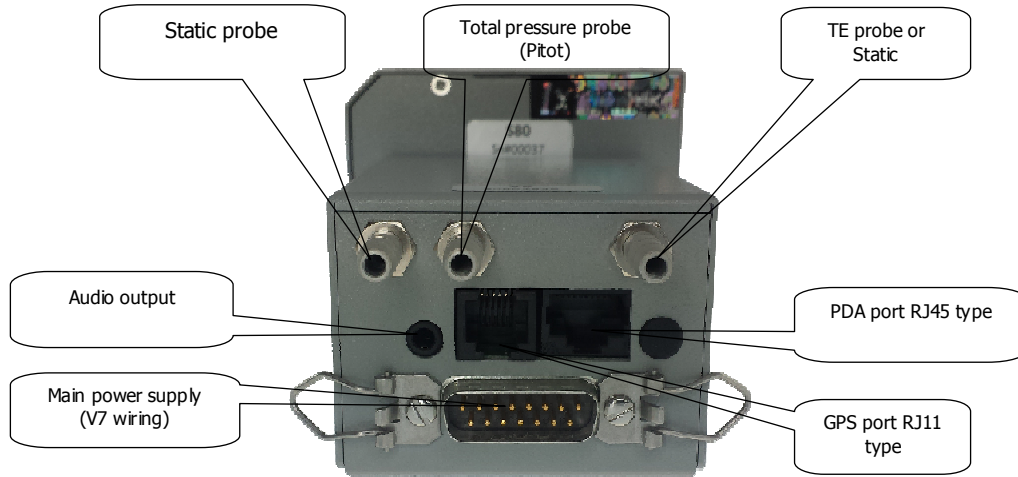

#### 8.6.1.1 PDA port (RJ45)

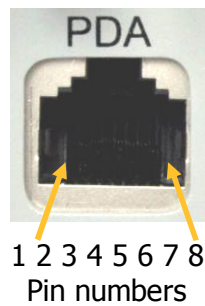

Pin number	Description
1,2	Ground
3	(output) Transmit from LXNAV S80 RS232 (e.g. Computer, IPAQ38/39xx)
4	(input) Receive to LXNAV S80 RS232 (e.g. Computer, IPAQ38/39xx)
5	(output) Transmit from LXNAV S80 LV-TTL (3.3V) (e.g. Oudie, HP302, HP31x)
6	(input) Receive to LXNAV S80 LV-TTL (3.3V) (e.g. Oudie, HP302, HP31x)
7,8	5V OUTPUT (maximum 1A)



RJ45 plug is NOT designed in accordance with IGC standard. It can be used only with dedicated cable. Do not plug unknown cable to it as it may damage LXNAV S80 unit.



### 8.6.1.2 GPS port (RJ11)



Pin number	Description
1	(output) 12V DC, to supply GPS
2,3	N.C.
4	(input) Receive to LXNAV S80 RS232 (e.g.NANO power 232)
5	(output) Transmit from LXNAV S80 RS232 (e.g.NANO power 232)
6	Ground

### 8.6.1.3 Main port

The main port is used to connect the S80 to the main wiring loom.

### 8.6.1.4 Audio port

The supplied speaker is connected with a standard 3mm phono jack.



This port is designed to be connected with an 8 ohm speaker supplied with the S80. Please consult with your dealer, if you want to make a different connection.

## 8.6.2 LXNAV S80 wiring

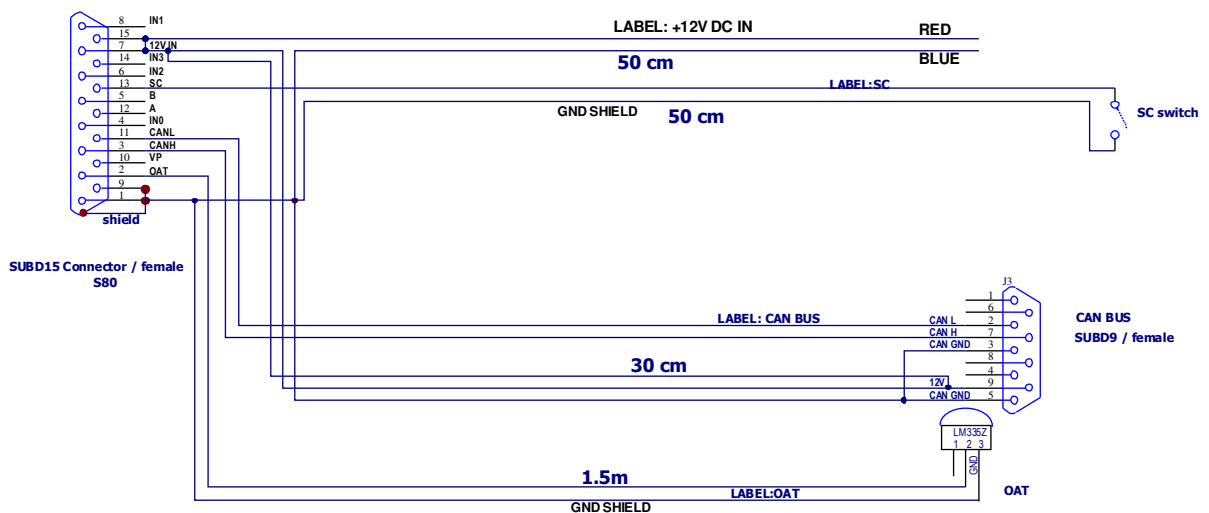

If a CAN BUS cable is not connected to an LXNAV S80D, the CAN connector must be terminated with a CAN TERMINATOR!

## 8.7 Configurations

### 8.7.1 NANO – S80 – OUDIE

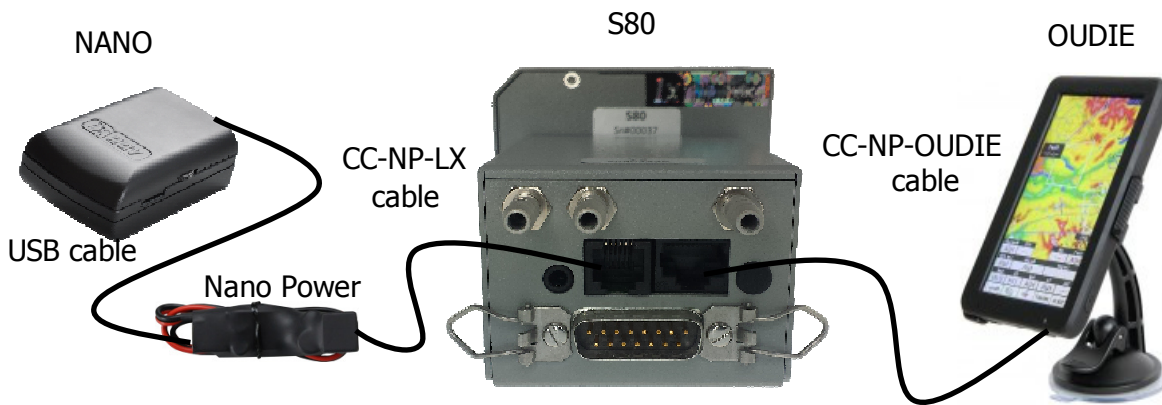

### 8.7.2 NANO – S80 – MINIMAP

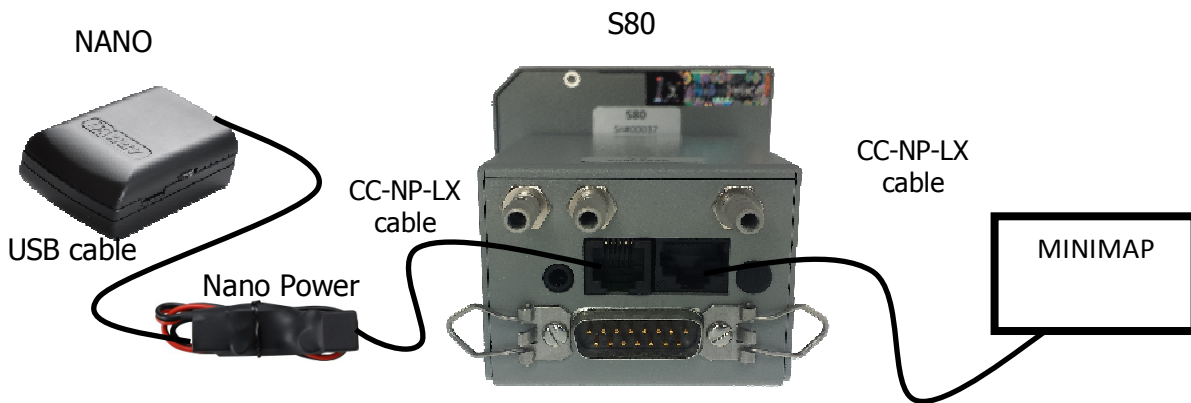

### 8.7.3 Nano3– S80 – OUDIE

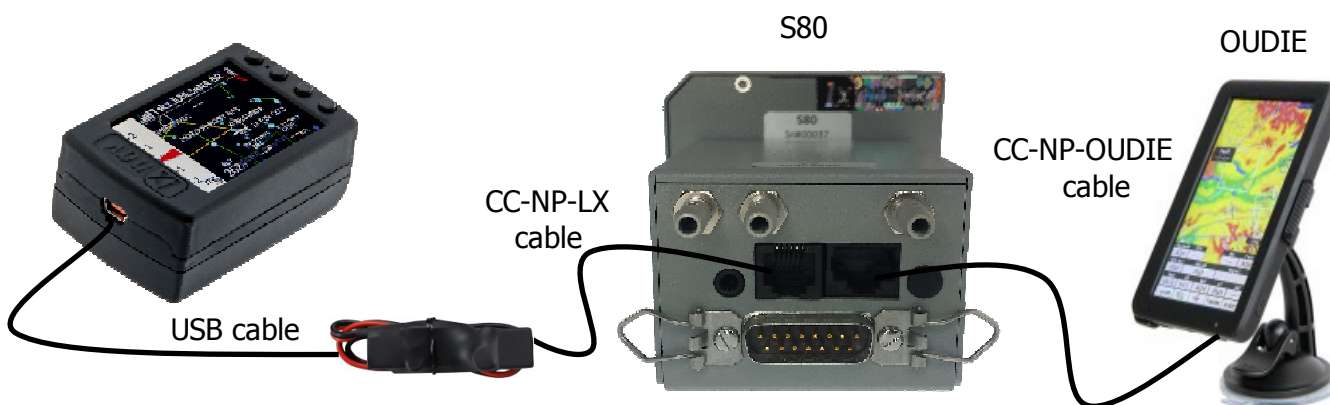

### 8.7.4 COLIBRI2 – S80 – OUDIE

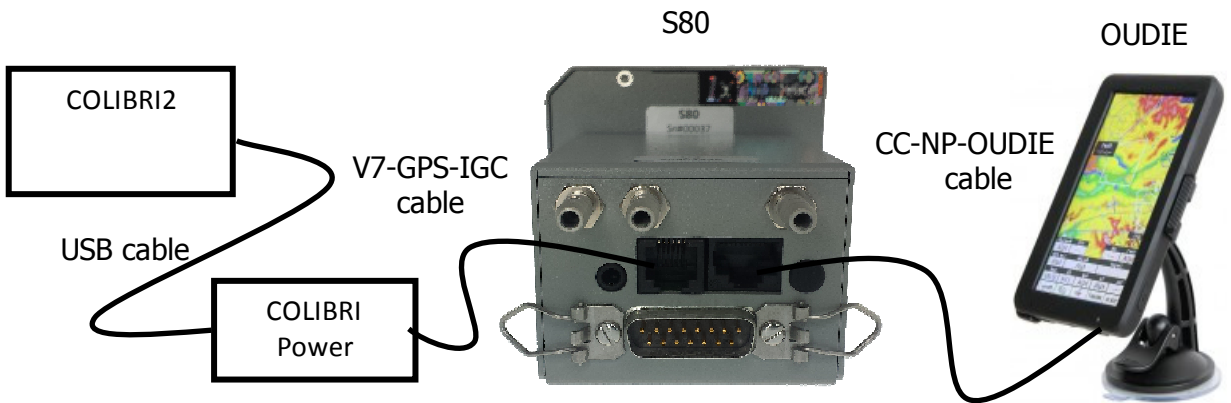

### 8.7.5 COLIBRI,VOLKSLOGGER– S80 – OUDIE

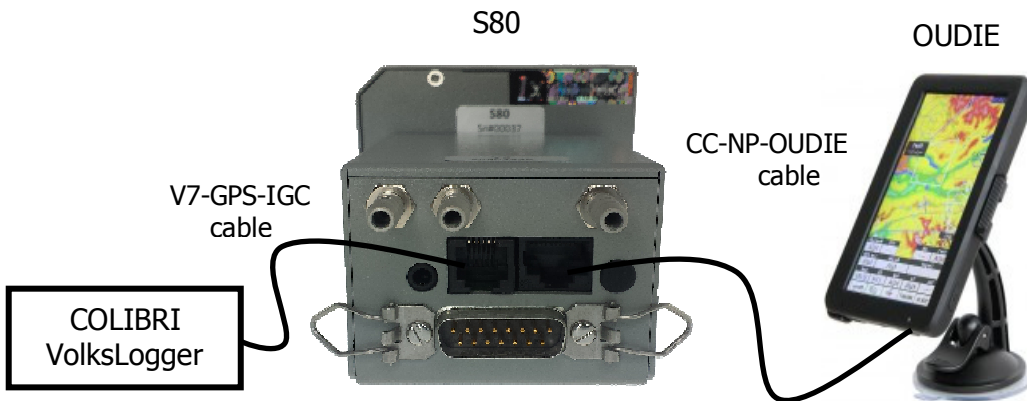

### 8.7.6 Flarm/RedBox– S80 – OUDIE

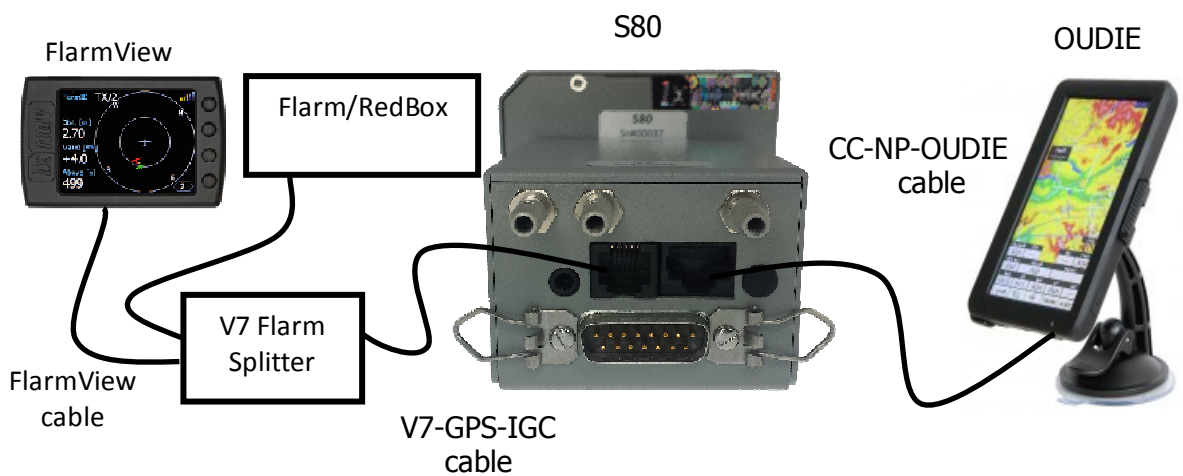

**8.7.7 FlarmMouse - FlarmView -S80 - OUDIE**

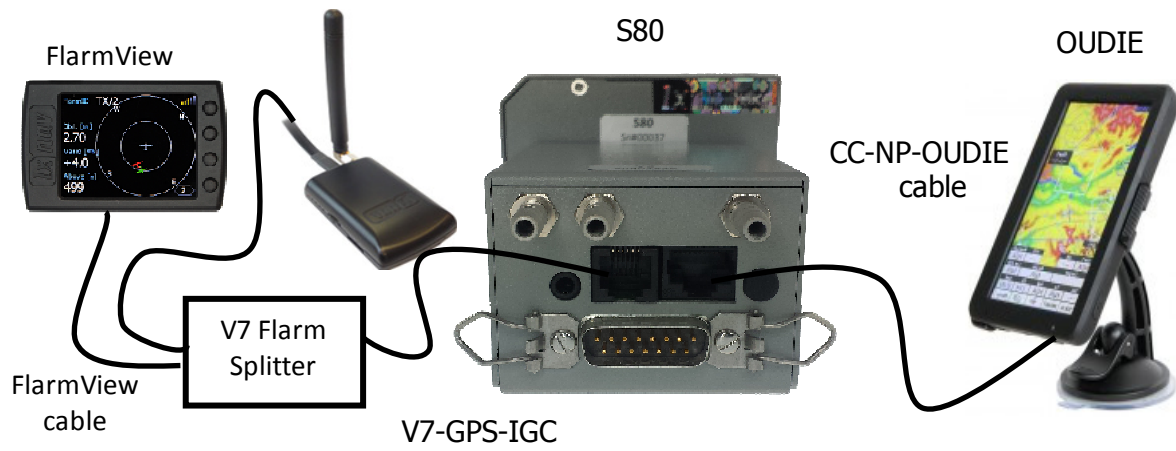

**8.7.8 FlarmMouse – S80 – OUDIE**

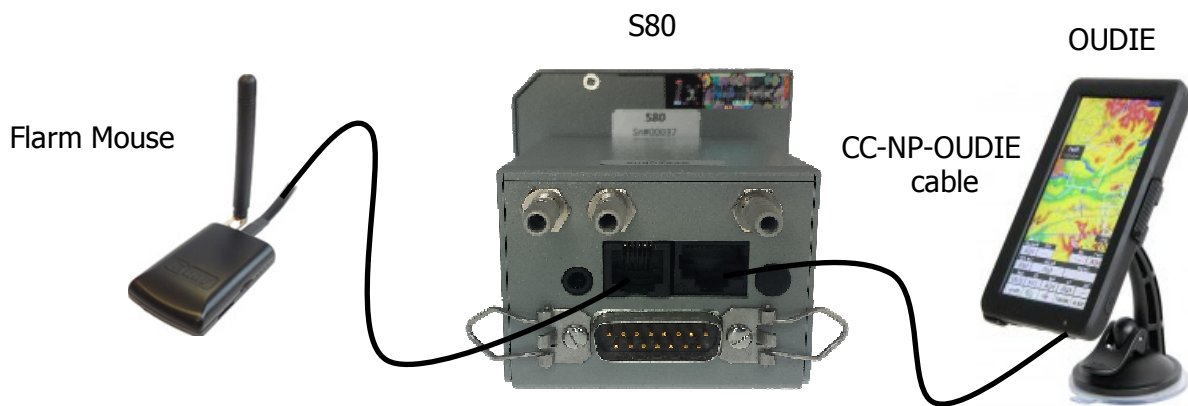

## 9 Firmware Update

Firmware updates for the main display indicator and vario unit can be easily carried out using the micro SD Card. Please visit our webpage [www.lxnav.com](http://www.lxnav.com) and download the firmware update.

You can also subscribe to a newsletter to receive news about the system automatically.

### 9.1 Updating LXNAV S80 firmware using micro SD card

Transfer the Firmware update files to the micro SD card and insert it into the S80. You should receive a message that the SD card has been loaded.

Go to Setup screen and select the password option.

Enter the password 89891, this will bring you to the firmware update menu.

Choose the right firmware for vario part and press update.

To update display part, S80 must be restarted.

Firmware fro vario has name NINB, firmware for display part has name V80C.

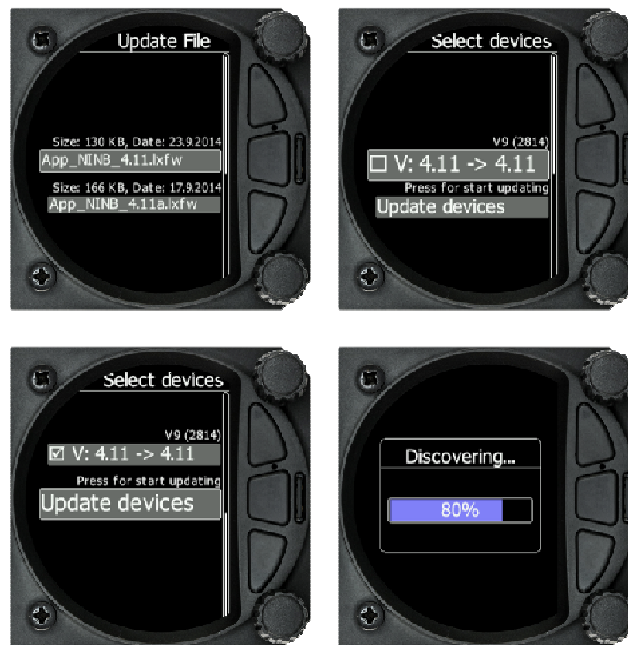

## 10 Revision History

October 2014	Initial release ver 4.9
November 2014	Updated chapters 8.5.1,8.5.2,8.5.3
December 2014	Updated chapters 5.3.2, 5.5.1.2, 7.2.1
January 2015	Updated chapter 5.6.12
January 2015	Typos, release 4.97a
January 2015	New cables for PDA and GPS port ch.8.4
March 2015	New sections for thermaling assistant and logbook